

RVE1000 Series Medium Voltage Drive

user's manual



Prior to use, please read this User's Manual carefully.

CAUTION: Please keep this User's Manual for future reference

RVE1000 Series Medium Voltage Drive User's Manual

V24.07

目录

1.Foreword	1
1.1 Guarantee period	1
1.2 Guarantee coverage	1
1.3 Beyond warranty liability	2
2.Usage instructions	3
2.1 Safety Instructions	3
Transportation, Storage	4
2.2 Unpacking and Inspection	5
2.3 Model designation	5
2.4 Drive nameplate description	6
2.5 Disposal precautions	6
3.Product description	7
3.1 Technical Features	7
3.2 Functional Introduction	11
3.3 Drive composition and working principle	14
3.4 Technical parameters of RVE1000 series medium voltage drive ..	22
3.5 Product Specifications and Dimensions	23
4.Installation and Connection	28
4.1 Acceptance	28
4.2 Transportation	28
4.3 Installation	30
4.4 Wiring	32
5.Touchscreen	34
5.1 Introduction to the touch screen	34
5.2 Touch screen operation	34
6. Function parameter table	52
6.1 Function group classification	52
6.2 Function List and Description	52
7.Debugging steps	69
7.1 Pre-commissioning instructions	69

7.2 Visual inspection before power-on	71
7.3 Insulation resistance inspection	72
7.4 Power unit and communication test	73
7.5 Drive test without motor	74
7.6 Drive with motor test	74
7.7 Important parameter setting instructions	77
8. Alarm information and troubleshooting	79
8.1 Fault code and fault name	79
8.2 Faults and countermeasures	79
9. Communication protocol	91
9.1 MODBUS function and address	91
9.2 Profibus Protocol	97
Appendix A Fault List	103
Appendix B Customer Complaint	109
APPENDIX C:QUALITY CERTIFICATION AND WARRANTY LETTER CARD ..	111
Appendix D Letter to Customers	113

1.Foreword

Thank you very much for purchasing the RVE1000 series medium voltage drive vector drive.

To ensure the correct installation and use of the RVE1000 series medium voltage drive, please read this instruction manual carefully and use the product after understanding the safety precautions of the product.

General Statement

During the editing process, our company reviewed the consistency of the contents of this manual with the hardware and software described. However, there may still be omissions. We will regularly check the contents covered in this manual and make necessary corrections in later revised versions. Suggestions for improvement are welcome.

This manual may not be copied, transmitted, transcribed, stored in a retrievable system, or translated into any language in any form without our written permission. Violators will be legally liable for the damage caused.

Our company's manuals are printed on chlorine-free paper, which is produced from sustainable forests. No chemical solvents are used in the printing and binding process.

The right to modify this manual without prior notice is reserved.

1.1 Guarantee period

The warranty period of the product is 18 months from the date of delivery to you or your company's customers, or 24 months from the date of shipment from the factory, whichever comes first.

1.2 Guarantee coverage

1.2.1 Troubleshooting

In principle, the initial fault diagnosis is performed by the user.

However, upon the user's request, our company service network may provide paid services.

At this time, based on the results of consultation with the user, if the cause of the failure is on our side, the service will be free of charge.

1.2.2 Breakdown repair

If the fault occurs and repair or product replacement is required, the company can send personnel to provide free door-to-door service. However, the following situations are charged services:

- The fault is caused by improper storage, use or design of the user and its customers.
- The user privately modifies the product without our company's knowledge and causes the fault.
- The fault is caused by using it outside the specification range of our company's products.
- The fault is caused by natural disasters and fires.
- Other reasons that are not our company's responsibility cause the fault.

1.3 Beyond warranty liability

The inconvenience caused to users and their customers due to the failure of our company's products, as well as the damage caused to non-our products, are not covered by our company's warranty, regardless of whether they are within the warranty period.

Our company does not assume any responsibility for joint losses.

Safety related marking instructions

In this manual, the following symbols are used for safety-related content. The contents of the statements with safety symbols are important and must be followed.



Improper use may cause dangerous situations that may result in personal injury or death.



Improper use may cause danger and may result in minor or serious personal injury and equipment damage.



These are the parts that users need to follow and pay special attention to.

2.Usage instructions

2.1 Safety Instructions



Important

- (1) Before installation, wiring, operation, maintenance and inspection, you must be familiar with the contents of this manual to ensure correct use. When using, you must also be familiar with the conditions of the driven machinery and process and all relevant safety precautions.
- (2) This series of medium-voltage drive is only suitable for three-phase medium-voltage induction motors and cannot be used for other purposes, otherwise there will be unpredictable failures or dangers.
- (3) Please dispose of discarded components and parts as industrial waste.



Wiring related

- (1) Wiring work must be carried out under the guidance of our professional personnel or in accordance with the guidance documents authorized by our company and in accordance with the electrical safety work standards.
- (2) On the power supply side of the medium-voltage drive, a medium-voltage circuit breaker for circuit protection must be used.
- (3) Wiring work can only be carried out after the equipment body is installed in place.
- (4) The ground wire must be reliably connected.
- (5) The number of phases of the input power must be confirmed, and the rated input voltage should be consistent with the rated value of the drive.

Transportation, Storage

- (1) During transportation, storage and installation, water must not enter the drive, otherwise it will cause damage to the equipment.
- (2) When lifting the equipment, ensure that the lifting equipment has sufficient load-bearing capacity and the lifting and lowering process should be smooth.
- (3) When moving, transporting and placing the equipment, the equipment should be placed horizontally and flatly.
- (4) Do not install or operate the drive if its components are damaged.
- (5) Install guardrails (marked with medium voltage danger signs) at necessary locations and do not remove them during equipment operation.
- (6) Do not leave foreign objects such as wire ends, paper scraps, metal shavings, tools, etc. in the drive.

Storage Note!

 Notice			
× Rainwater	× Outdoor	× Conductive dust	× Direct sunlight
× Flammable and explosive gases	× Corrosive gas		
× Salt, oil smoke and dust, etc.			



- (1) Operation can only be carried out after confirming that there is no voltage input to the control circuit and the main circuit.
- (2) The input and output medium-voltage cables must be connected according to the instructions and must not be connected incorrectly, otherwise it may cause damage to the equipment.
- (3) The input and output medium-voltage cables must meet the requirements of insulation and current carrying capacity, otherwise there is a risk of short circuit when powered on.

(4) The drive should be installed on flame retardant materials, such as metal brackets and concrete floors.

(5) The drive must be operated by a medium-voltage electrician when medium voltage is applied. After power is applied, the doors of the cabinet other than the control cabinet must not be opened.

2.2 Unpacking and Inspection



© Do not install a damaged drive or one that is missing parts.
Otherwise, there is a risk of fire or personal injury.

When unpacking, please carefully check whether there is any damage during transportation; whether the model and specifications on the nameplate of the machine are consistent with the order requirements. If you find that the model does not match or components are missing, please contact the manufacturer or supplier as soon as possible to resolve the problem

2.3 Model designation

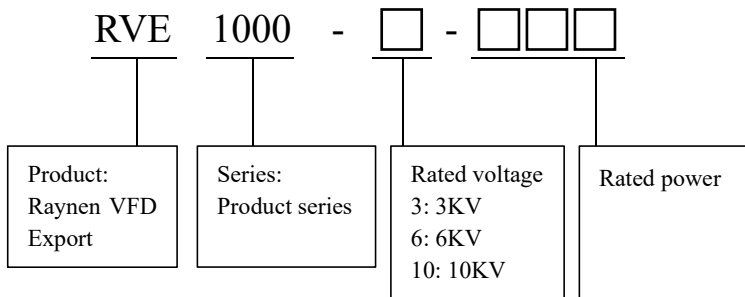

Figure 2-1 Model Description

2.4 Drive nameplate description

The drive nameplate is shown in Figure 2-2.

The drive nameplate contains the drive model, specifications, machine number, sales order number and other information.

RVE1000 Series Medium Voltage drive					
Product model:	<input type="text"/>	Output voltage:	<input type="text"/>	VAC	
Input voltage:	<input type="text"/>	VAC	Output frequency:	<input type="text"/>	Hz
Input frequency:	<input type="text"/>	Hz	Applicable motor:	<input type="text"/>	kW
Input current:	<input type="text"/>	kW	Ambient temperature:	<input type="text"/>	
Product number:	<input type="text"/>	Manufacture date:	<input type="text"/>		

Figure 2-2 Drive nameplate

2.5 Disposal precautions

Discarded components and parts should be treated as industrial waste.

2.5.1 Disposal of capacitors

The electrolytic capacitors in the main circuit and the electrolytic capacitors on the printed board may explode when burned. Therefore, it is forbidden to burn capacitors.

2.5.2 Disposal of plastic parts

There are many plastic parts on the drive, and toxic gases will be generated when the plastic parts are burned. Therefore, it is forbidden to burn plastic parts.

3.Product description

3.1 Technical Features

RVE1000 series medium voltage drive is a new generation of medium voltage source drive designed and manufactured by our company. It suppresses the grid-side input harmonics through phase-shifting rectifier transformers, realizes voltage superposition through multi-stage H-bridge power unit cascade, and obtains perfect medium voltage sine wave output, directly driving medium voltage motors without adding any filters. RVE1000 series medium voltage drive is not only suitable for standard medium voltage (3kV, 6kV, 10kV) three-phase AC motors, but also can be customized according to the user's grid voltage. Non-standard products can be directly used to drive medium voltage permanent magnet synchronous motors. RVE1000 series medium voltage drive has the following characteristics:

3.1.1 High-quality input characteristics

RVE1000 series medium voltage drive adopts phase-shifted multiple rectification technology on the power supply side, with low harmonic pollution on the grid side and high power factor, which meets the requirements of GB 14549-93 standard and IEEE std 519-1992 power quality standard for voltage and current harmonic distortion, and does not generate harmonic interference to other electrical equipment on the same grid. As shown in Figure 3-1 and Figure 3-2.

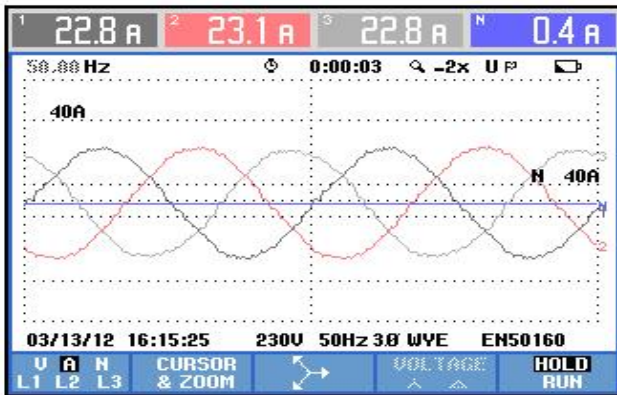

Figure 3-1 Input three-phase current waveform

Harmonic table				
Amp	L1	L2	L3	N
THD%f	2.5	2.4	2.4	440.1
H3%f	1.1	1.1	1.2	65.1
H5%f	1.7	1.6	1.6	67.7
H7%f	0.8	0.8	0.8	66.8
H9%f	0.1	0.1	0.1	72.8
H11%f	0.9	0.9	0.9	62.5
H13%f	0.2	0.2	0.2	64.9
H15%f	0.1	0.1	0.1	71.4

03/13/12 16:14:25	230V 50Hz 3Ø WYE	EN50160
U A W U&A	HARMONIC GRAPH	TREND HOLD RUN

Figure 3-2 Total harmonics of input three-phase current

3.1.2 Low output harmonics

The output side of the RVE1000 series medium voltage drive adopts phase-shifted pulse width modulation technology, and the output harmonics are very small, and it can adapt to various motors without output filtering devices. The output voltage distortion is low and the waveform is good. Therefore, the motor has low running noise, small torque pulsation, low heat generation, and a large output cable length range.

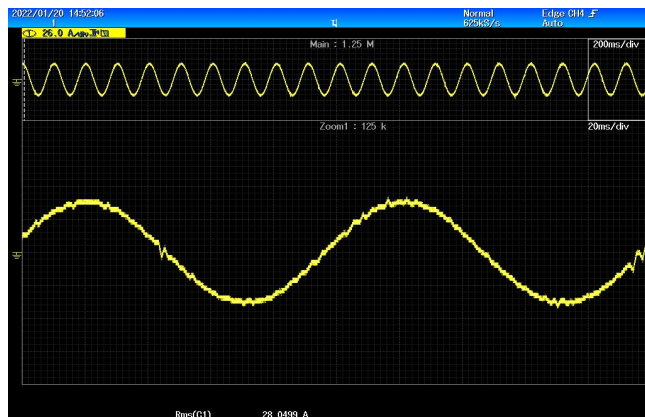

Figure 3-3 Output sinusoidal current waveform

3.1.3 High power factor

RVE1000 series medium voltage drive is a constant voltage source type. It can maintain a high power factor in the full speed range. The full load power factor can reach above 0.95, thereby reducing the low utilization rate of user power transformer equipment and the power factor compensation problem at the user end caused by low power factor. Figure 3-4 is a comparison of the power factor of medium voltage drive and phase-controlled thyristor.

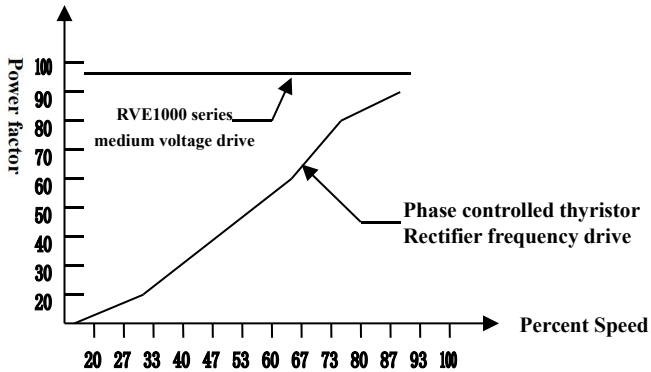

Figure 3-4 Power factor comparison between RVE1000 series medium voltage drive and phase controlled thyristor

3.1.4 Power-off endurance

During system operation, after the grid loses power instantly (within 1.2 seconds), the drive is guaranteed to last for 1.2 seconds without stopping. If it is powered on again during this time, it can continue to operate, avoiding losses caused by unnecessary downtime. If the time is exceeded, a power-off fault will be reported and the system will shut down.

3.1.5 High reliability and easy maintenance

The IGBT power module of the RVE1000 series medium voltage drive has a large voltage and current design margin. The triggering and overcurrent protection of the IGBT module adopts a dedicated drive module circuit, which has extremely high reliability. The control signal of the drive is transmitted by optical fiber, realizing reliable electrical isolation of medium voltage and low voltage weak current.

The RVE1000 series medium voltage driver adopts modular design, with perfect structural process design. The power unit of the same capacity is universal. If a fault occurs, it can be replaced within a few minutes using simple tools, which is very convenient and fast.

3.1.6 Alarm and fault protection function

The RVE1000 series drive provides a very rich alarm and protection function. Including the fault information of the whole machine and the fault information related to the power unit, these fault information can be conveniently and quickly queried through the remote monitoring interface or the on-site touch screen.

When a fault occurs, the drive can automatically record the operating environment information of the fault.

3.1.7 Select the power unit bypass function

When a power unit of the drive fails, it can be bypassed through the bypass function, and the drive runs at a reduced rating.

Greatly improve the reliability of the drive. To replace the faulty power unit, the drive must be shut down and the medium voltage input power of the drive must be cut off.

3.1.8 Select the system variable frequency/power frequency switching

In the case of process requirements or medium voltage drive failure, the user can select manual or automatic system variable frequency/power frequency switching through the function parameters.

3.1.9 Soft start function

The RVE1000 series medium voltage drive has a soft start function. The starting time is set by the user, and the internal acceleration overcurrent limiting function is set to suppress the impact current of the motor start, ensure the safe operation of the motor, and extend its service life. It can achieve rapid start without overcurrent impact on the power grid and the motor. This function can also effectively reduce the mechanical failure rate such as motor cage bar breakage.

3.1.10 Reduce motor wear and save maintenance costs

Loads such as fans and pumps use RVE1000 series medium voltage drive to adjust the motor speed to adjust the output, which can not only achieve the purpose of energy saving, but also greatly reduce the mechanical wear of the motor and its load, saving maintenance costs for users.

3.1.11 Rich user terminal interface

RVE1000 series medium voltage drive provide rich I/O ports for users to use. Users can use these I/O ports provided by the system (4 analog inputs, 4 analog outputs, 16 switch inputs, 8 relay outputs) to build specific application systems; and some are programmable terminals, thus ensuring that the system has good adaptability. I/O ports can also be expanded according to actual user needs.

3.1.12 Friendly human-machine interface

RVE1000 series medium voltage drive use touch screen configuration for human-machine interaction; rich settings, display, and operation functions, and a friendly human-machine interface. The user can easily understand the system's operating status information through the human-machine interface and control the medium voltage drive according to the process control requirements.

3.2 Functional Introduction

3.2.1 Frequency Setting

Operation frequency setting method:

- (1) Panel setting.
- (2) Communication setting (this solution is used for the remote monitoring interface).
- (3) Analog signal input setting.
- (4) Multi-speed setting: The drive can set multiple frequency bands, as well as acceleration and deceleration time, and switch between these frequency bands flexibly by terminal selection. The settings related to the operating frequency can be configured by selecting the relevant parameters in the digital multi-speed parameters; the selection of the frequency setting method can be set through the "frequency/speed channel selection parameter".

3.2.2 Operation control method

The drive's starting methods are:

- (1) Normal start.
- (2) DC braking first and then starting. For fans that may be driven by load to reverse, the motor can be stopped by DC braking before starting, thereby avoiding huge impact current during starting.
- (3) Speed tracking start. Also known as flying start. The drive first tracks the current speed of the motor, and then starts directly based on the current motor speed.

The parking modes are:

- (1) Deceleration parking. Control the motor speed to decrease according to the deceleration curve, and stop when the frequency reaches zero.
- (2) Inertia parking. Directly block the PWM output, and the motor stops according to its own inertia.
- (3) DC braking parking. Rapid braking parking is achieved by adding DC to the motor coil.

There are several ways to give the start and stop commands of the drive:

- (1) Panel control.
- (2) Terminal control.
- (3) Communication control.

The setting of the setting method of the start and stop command can be set through the touch screen.

3.2.3 Acceleration and deceleration protection function

Protect the motor from overcurrent during acceleration and overvoltage during deceleration. Once an overcurrent or overvoltage alarm occurs (has not yet reached the protection value), the drive will automatically maintain the current frequency unchanged until the current or voltage returns to normal levels and then continue the acceleration or deceleration process.

3.2.4 Frequency Hopping Function

RVE1000 series drive supports the setting of skip frequency, and there are three skip frequency points available.

(1) Skip frequency: In order to avoid the damage to the motor and other equipment when the drive runs at the resonance point of the mechanical equipment, the user can avoid the resonance point by setting the skip frequency.

(2) Frequency Hopping Bandwidth: The frequency width that the drive jumps over when hopping. It is generally recommended that this bandwidth should not be too large. It is recommended to be between (0.5-2). If it is set too large, it is easy to cause over current or over voltage faults.

3.2.5 Torque boost function of V/F control

RVE1000 series medium voltage drive provides low-frequency torque boost function. Users can use the corresponding parameters in the custom V/F parameters to set the torque boost amplitude and the speed range that requires torque boost.

3.2.6 Configuration of programmable user terminals

RVE1000 series medium voltage drive provides users with rich terminal functions. In addition, I/O ports can be expanded according to the actual needs of users. These ports are programmable ports, thus ensuring the system has flexible scalability and good adaptability.

3.2.7 Real-time monitoring function of operating parameters

RVE1000 series medium voltage drive has rich parameter monitoring functions.

In any state, it can monitor the operating frequency, given frequency, current speed, input voltage, output voltage, input current, output current, operating speed, output power, terminal status, analog value, unit bus voltage, unit temperature, unit optical fiber communication status, unit operating status, unit bypass status, transformer temperature, etc.

3.2.8 Comprehensive fault inspection and protection function

RVE1000 series medium voltage drive provides more than 220 fault classification protection, and will automatically alarm or report fault processing and recording according to the severity of the fault. Users can view fault information through the

operator or remote monitoring interface. The system also provides an alarm prompt interface to avoid damage to components due to serious faults.

In addition, the system provides EEPROM detection function. When the system detects an EEPROM error, it will prompt the user through the remote monitoring interface.

3.2.9 Multi-level user authority management

RVE1000 series medium voltage drive provides multi-level user authority, and provides corresponding authority according to user level, so as to make operation safer and more convenient.

3.2.10 Convenient parameter backup function

The remote monitoring interface also provides a very convenient parameter and other configuration information backup function. Users can restore the backed-up parameters to the system through simple operations.

3.2.11 Communication function

RVE1000 series medium voltage drive provides external communication interfaces for Modbus (standard) and Profibus-DP (optional). Users can use their own system to control and set the drive through the protocol.

3.3 Drive composition and working principle

3.3.1 Composition

The standard configuration of RVE1000 series drive varies according to the drive, unit number and model, and other factors. But they are generally composed of the following cabinets.

- Transformer cabinet
- System control cabinet
- Power unit cabinet
- System bypass cabinet (user optional)
- Starter cabinet (user optional)

Figure 3-5 is a typical RVE1000 drive appearance

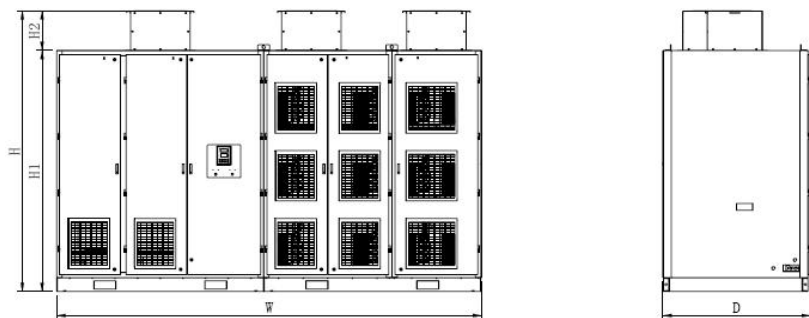

Figure 3-5 Appearance of RVE1000 series drive

3.3.1.1 Transformer Cabinet

The transformer part of the RVE1000 drive mainly includes a phase-shifting rectifier transformer and a transformer cabinet. The input power line enters the drive from this cabinet, and the output power line to the motor also leads out from this cabinet. The input and output power lines can be either top-in or bottom-in. The transformer part also includes one or more fans to cool the transformer. See Figure 3-6.

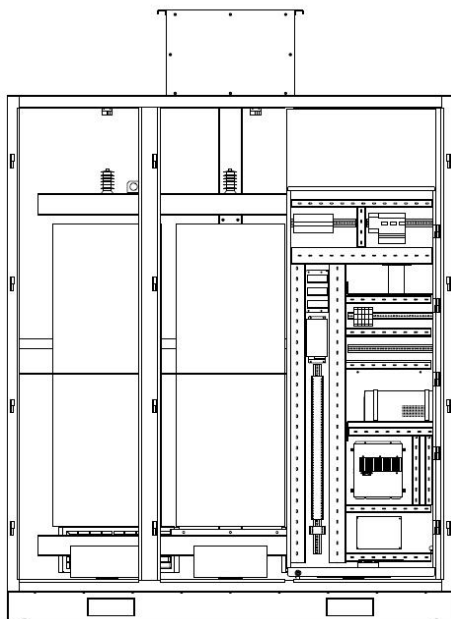

Figure 3-6 Transformer cabinet interior

3.3.1.2 System Control Cabinet

The system control part is contained in the control cabinet, and the cabinet door of the control cabinet can be opened during operation. This part mainly includes: the main control system composed of a microprocessor (ARM) and a field-programmable logic gate array (FPGA), the drive status signal acquisition system, and the low-voltage power supply system composed of a UPS and a switching power supply.

3.3.1.3 Power Unit Cabinet

The power unit is a key component of system rectification and inversion. It is mainly composed of a rectifier bridge, an energy storage capacitor, and an IGBT. Each level of the power unit provides a level of output voltage. The series output of multiple units realizes the transition from low voltage to medium voltage. See Figure 3-7.

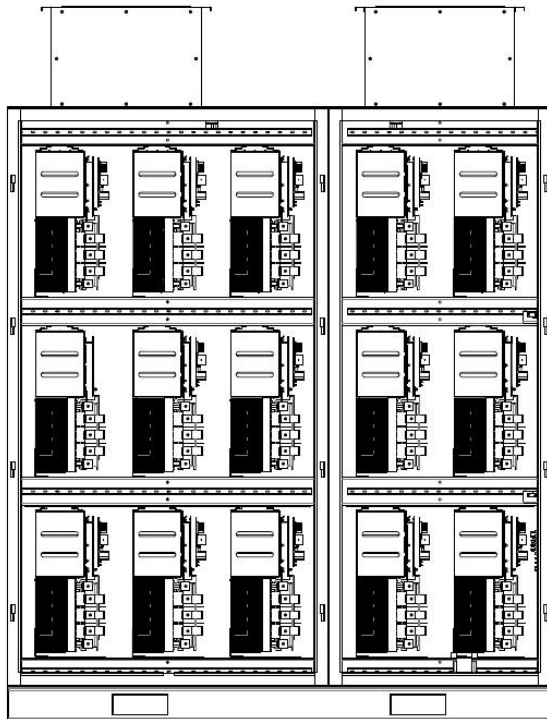

Figure 3-7 Internal view of the power unit cabinet

3.3.1.4 System bypass cabinet (user optional)

The user can select the system bypass function according to the actual application on site. The main part of the system bypass is the system bypass cabinet. The main function of the system bypass is to directly put the motor into the power frequency power grid when the drive fails to ensure the continuity of production and improve the stability of the system. There are two basic configurations of the system bypass cabinet: one is a manual bypass cabinet and the other is an automatic bypass cabinet. If there are special requirements for bypass, please indicate them in the technical agreement.

3.3.1.5 Starting cabinet (user optional)

When the drive is powered on at medium voltage, the excitation current of the phase-shifting isolation transformer at the moment of power-on and the charging current of the DC bus capacitor circuit of each unit will be very large, causing the upper power cabinet to malfunction quickly. The use of a starting cabinet can effectively avoid this situation.

3.3.2 Working principle

3.3.2.1 Main circuit

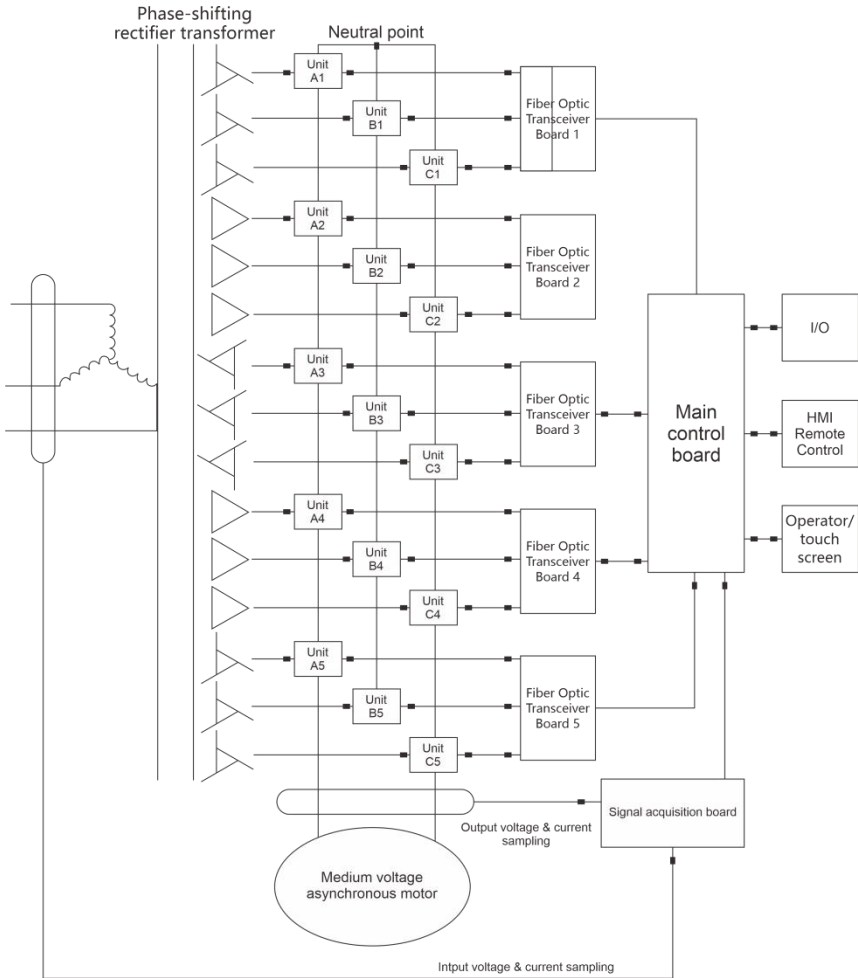

Figure 3-8 Schematic diagram of medium voltage drive system (taking 6kV as an example)

Figure 3-8 shows a typical circuit topology of a 6kV RVE1000 series drive, using a 690V power unit. Each phase of the motor is driven by five power units in series, with a phase voltage of $5 \times 690 = 3450\text{V}$ and a line voltage of $3450 \times 1.732 \approx 6000\text{V}$. The series connection adopts a star connection with a floating neutral point. Each power unit is

powered by an isolated secondary winding of an isolation transformer. The rated voltage of each of the fifteen secondary windings is 690VAC, and the power of each power unit is one-fifteenth of the total power. As shown in Figure 2-8, the insulation level between the A, B, and C three-phase units is 6kV, and the insulation level of all units to the ground is 6kV.

3.3.2.2 Power Unit

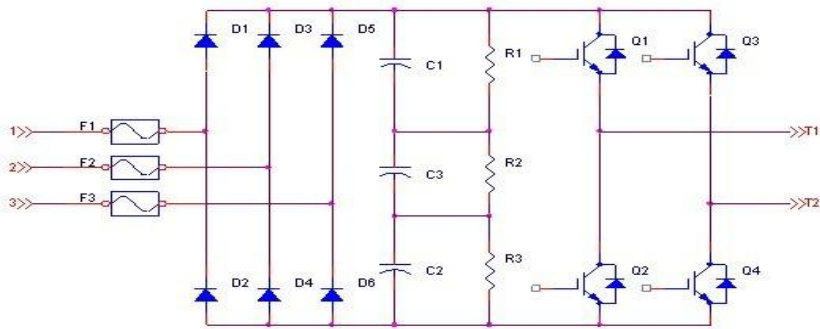

Figure 3-9 Power unit topology diagram

Figure 3-9 shows the electrical topology diagram of the power unit. It is divided into three parts: the first part is the rectifier part, which is a three-phase 690V input and becomes DC after three-phase uncontrolled rectification. The second part is the DC bus part, the main components of which are large-capacity electrolytic capacitors and voltage-equalizing resistors. The third part is the drive part, which adopts the H-bridge drive method and the power device is IGBT.

3.3.2.3 Control System

The block diagram in Figure 2-8 shows how the RVE1000 drive control system is implemented. The control system consists of a main control board, a fiber optic transceiver board, a signal acquisition board, I/O, an operator/touch screen, and a remote monitoring interface.

The main control system uses a microprocessor (ARM) + field-programmable logic gate array (FPGA) to generate a three-phase voltage command of pulse width modulation (PWM) using a sinusoidal space vector algorithm to control the motor.

The fiber optic transceiver board is used to convert optical signals and electrical signals. It converts the electrical signal from the main control into an optical signal and sends it to the corresponding power unit. It also collects real-time information from the power unit, then converts it into an electrical signal and transmits it to the main control board. So that the main control can make control actions in time.

The signal acquisition board collects current signals and voltage signals from the input and output sides, processes the data, and transmits them to the main control board. These voltage and current signals are important bases for control. They are also important bases for issuing overcurrent, overvoltage, and other alarms or emergency stops.

The I/O port provides interfaces for input and output of various digital and analog quantities. The signals it collects are important basis for control and can make corresponding actions. For example, external analog quantity given, multi-speed digital quantity given, PID feedback signal, drive self-state detection and other information.

The touch screen is a standard configuration of the drive. It can not only issue various commands, but also comprehensively monitor and record various states from power unit to the whole machine, and can easily view and modify the drive parameters.

3.3.2.4 System bypass (optional)

As mentioned above, the function of the system bypass is to switch the motor to the power frequency grid when the drive fails. It is divided into two configurations: automatic bypass and manual bypass. The primary schematic diagram is shown in Figure 3-10 and Figure 3-11. KM2 and KM3 in the automatic bypass cabinet use vacuum contactors with mechanical interlocking. KM2 and KM3 cannot be closed at the same time to prevent the power frequency power supply from being directly sent to the drive output. QS2-1 and QS2-2 in the manual bypass cabinet are single-pole double-throw knife switches, which can also prevent the power frequency power supply from being directly sent to the drive output.

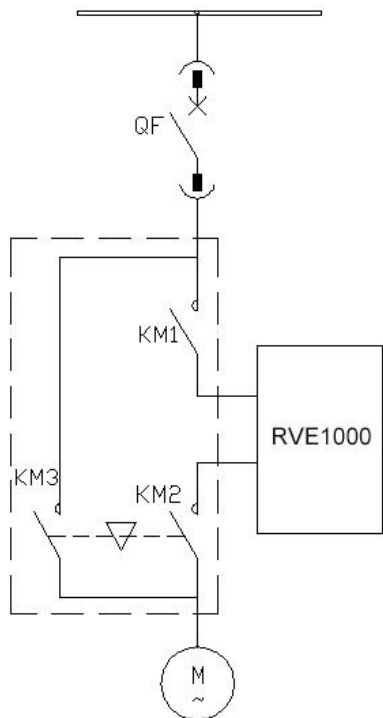

Figure 3-10 Primary electrical diagram of the automatic system bypass cabinet

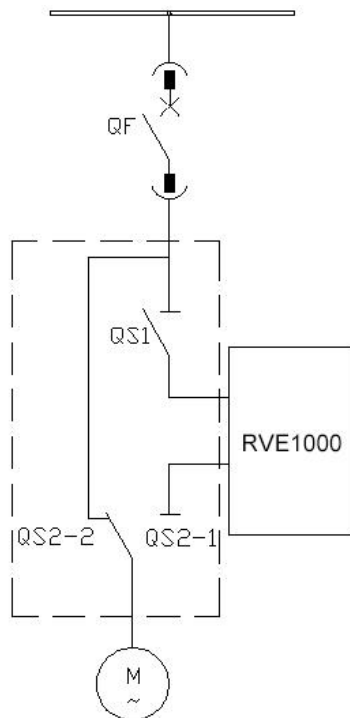

Figure 3-11 Primary electrical diagram of the manual system bypass cabinet

3.4 Technical parameters of RVE1000 series medium voltage drive

Table 3-1 lists the technical parameters of the RVE1000 series drive system.

Table 3-1 Common specifications of standard RVE1000 drive

	item	description
Mainly used standards	National Standard	GBT 24337-2009
	IEEE	STD519-2014
	Line Standard	DL/T994 -2006
Input Power	Input line voltage	3.0-35kV (-10%~+10%)
	Input voltage fluctuation	-35%~+15% rated voltage
	Input power frequency	50/60Hz±5%
	Input power factor	When the load exceeds 20%, it can reach above 0.95
	Control power supply	Three-phase four-wire system 380V, 5~50kVA (depending on the capacity of the drive)
Output Power	Output line voltage	0~11 kV
	Output frequency	0~300Hz
	Output frequency drift	±0.5%
	Output efficiency	≥96%
	Output frequency resolution	0.01Hz
Control performance	Speed range	0.01~300 Hz (Motor related)
	Overload capacity	120%, 60s (can be designed according to user requirements)
	control method	VF control/GVC control/torque control/vector control
	control precision	±0.5%
	Load torque characteristics	Square torque load, constant torque load
	Acceleration and deceleration time	0~3200S (adjusted according to load characteristics)
	Main protection functions	Overvoltage, overcurrent, short circuit, overheating, optical fiber communication, unit, etc.
Input and output capabilities	Digital input	16 digital inputs, expandable to 32
	Digital output	12 digital outputs, expandable to 28
	Analog input	4 analog inputs (0~10V/4~20ma)
	Analog output	6 analog outputs (0~10V/4~20ma)
	Communication function	Standard: Modbus; Optional: Profibus-DP, Profinet, TCP/IP, etc.
display	User Interface	Touch screen, support Chinese and English operation interface

item		description
Transformer characteristics	Temperature protection	130°C Failure
	Insulation class	H
Environmental conditions	Protection level	IP30
	cooling method	Forced air cooling
	Maintenance method	Front and rear maintenance
	Operating temperature	0~+50°C
	Storage and transportation temperature	-20°C~+70°C
	humidity	<95%, no condensation
	vibration	Below 0.9g
	Place of use	Indoors without corrosive, explosive gas, or dust.
Use Altitude	Altitude less than 3000 meters	

3.5 Product Specifications and Dimensions

The following technical indicators include the electrical selection information and cabinet dimensions of the RVE1000 series medium voltage drive, which can be used as an important reference for your selection! This information may be updated, please contact sales. If you choose a system bypass cabinet, the width of the one-to-one system bypass cabinet is 800mm, and the height and depth are the same as the drive.

Table 3-2 3kV RVE1000 series medium voltage drive specifications and dimensions

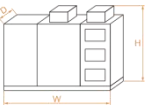
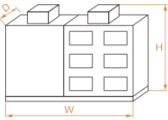
Schematic	drive power (kW)	Transformer capacity (kVA)	Output current (A)	Product number	Drive size (W*D*H mm)	gross weight (T)
	250	300	58	RVE1000-3-250	2025*1325*2480	2.0
	280	350	67	RVE1000-3-280	2025*1325*2480	2.0
	300	375	72	RVE1000-3-300	2025*1325*2480	2.0
	400	500	96	RVE1000-3-400	2300*1500*2480	2.3
	450	560	108	RVE1000-3-450	2300*1500*2480	2.3
	500	630	121	RVE1000-3-500	2300*1500*2480	2.4
	560	700	135	RVE1000-3-560	2300*1500*2480	2.5
	630	800	154	RVE1000-3-630	2300*1500*2480	2.6
	710	900	173	RVE1000-3-710	2300*1500*2480	2.6
	800	1000	192	RVE1000-3-800	2300*1500*2480	2.7

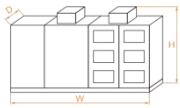
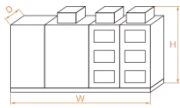
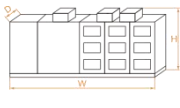
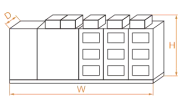
Schematic	drive power (kW)	Transformer capacity (kVA)	Output current (A)	Product number	Drive size (W*D*H mm)	gross weight (T)
	900	1120	216	RVE1000-3-900	2600*1500*2731	3.9
	1000	1250	241	RVE1000-3-1000	2600*1500*2731	4.1
	1120	1400	269	RVE1000-3-1120	3500*1500*2895	5.1
	1250	1600	301	RVE1000-3-1250	3500*1500*2895	5.3
	1400	1800	346	RVE1000-3-1400	3500*1500*2895	5.6
	1500	1900	366	RVE1000-3-1500	5534*1500*2916	7.0
	1600	2000	385	RVE1000-3-1600	5534*1500*2916	7.1
	1800	2250	433	RVE1000-3-1800	5534*1500*2916	7.2
	2000	2500	481	RVE1000-3-2000	5534*1500*2916	7.5
	2240	2800	539	RVE1000-3-2240	5534*1500*2916	8.0
	2500	3150	600	RVE1000-3-2500	5534*1500*2916	8.4
	2800	3500	670	RVE1000-3-2800	7382*1980*3438	10.4
	3150	3950	750	RVE1000-3-3150	7382*1980*3438	10.7
	3300	4130	800	RVE1000-3-3300	7382*1980*3438	11.2

Note: For loads above 800kW, please configure a starter cabinet. For loads above 2500kW, please contact our company.

Table 3-3 6kV RVE1000 series medium voltage drive specifications and dimensions

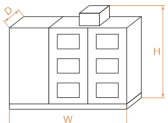

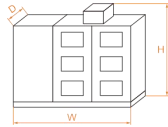
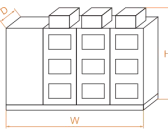
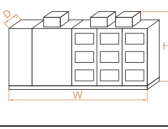
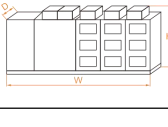
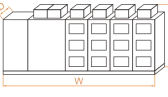
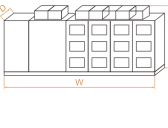
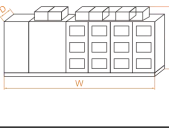
Schematic	drive power (kW)	Transformer capacity (kVA)	Output current (A)	Product number	Drive size (W*D*H mm)	gross weight (T)
	280	350	34	RVE1000-6-280	2700*1325*2542	2.1
	315	400	38	RVE1000-6-315	2700*1325*2542	2.1
	355	450	43	RVE1000-6-355	2700*1325*2542	2.2
	400	500	48	RVE1000-6-400	2700*1325*2542	2.3
	450	560	54	RVE1000-6-450	2700*1325*2542	2.4
	500	630	61	RVE1000-6-500	2700*1325*2542	2.5
	560	700	67	RVE1000-6-560	2700*1325*2542	2.6
	630	800	77	RVE1000-6-630	2700*1325*2542	2.8
	710	900	87	RVE1000-6-710	2700*1325*2542	3.1

Schematic	drive power (kW)	Transformer capacity (kVA)	Output current (A)	Product number	Drive size (W*D*H mm)	gross weight (T)
	800	1000	96	RVE1000-6-800	2700*1325*2542	3.3
	900	1120	108	RVE1000-6-900	2700*1325*2542	3.4
	1000	1250	120	RVE1000-6-1000	2700*1325*2542	3.5
	1120	1400	135	RVE1000-6-1120	2700*1325*2542	3.7
	1250	1600	154	RVE1000-6-1250	2700*1325*2542	3.8
	1400	1800	173	RVE1000-6-1400	2700*1325*2542	3.9
	1500	1900	183	RVE1000-6-1500	3000*1500*2542	4.4
	1600	2000	192	RVE1000-6-1600	3000*1500*2542	4.6
	1800	2250	217	RVE1000-6-1800	3500*1600*2731	6.7
	2000	2500	241	RVE1000-6-2000	3500*1600*2731	7.0
	2240	2800	269	RVE1000-6-2240	4405*1500*2895	9
	2500	3150	303	RVE1000-6-2500	4405*1500*2895	9
	2600	3300	318	RVE1000-6-2600	4405*1500*2895	9.8
	2800	3500	337	RVE1000-6-2800	4705*1600*2895	10.2
	3150	4000	385	RVE1000-6-3150	7434*1600*2916	12.9
	3550	4500	433	RVE1000-6-3550	7434*1600*2916	14
	4000	5000	481	RVE1000-6-4000	7434*1600*2916	14.3
	4500	5800	558	RVE1000-6-4500	7434*1600*2916	15.5
	5000	6300	600	RVE1000-6-5000	7434*1600*2916	16.7
	5600	7000	673	RVE1000-6-5600	9270*1980*3438	20.7
	6300	8000	770	RVE1000-6-6300	9270*1980*3438	20.7
	7100	9000	870	RVE1000-6-7100	9270*1980*3438	22.2
	8000	10000	962	RVE1000-6-8000	9270*1980*3438	22.2

Note: For loads above 1600kW, a starter cabinet is required. For loads above 8000kW, please contact our company for model selection.

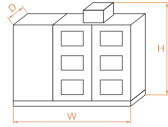
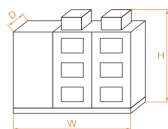
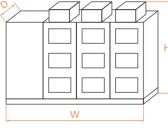
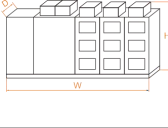
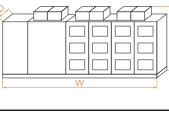
Table 3-4 10kV RVE1000 series medium voltage drive specifications and dimensions

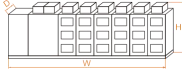
Schematic	drive power (kW)	Transformer capacity (kVA)	Output current (A)	Product number	Drive size (W*D*H mm)	gross weight (T)
	280	350	20	RVE1000-10-280	2700*1325*2542	2.4
	315	400	23	RVE1000-10-315	2700*1325*2542	2.5
	355	450	26	RVE1000-10-355	2700*1325*2542	2.5
	400	500	29	RVE1000-10-400	2700*1325*2542	2.6
	450	560	32	RVE1000-10-450	2700*1325*2542	2.6
	500	630	36	RVE1000-10-500	2700*1325*2542	2.7
	560	700	40	RVE1000-10-560	2700*1325*2500	2.8
	630	800	46	RVE1000-10-630	2700*1325*2500	2.9
	710	900	52	RVE1000-10-710	2700*1325*2500	2.9
	800	1000	58	RVE1000-10-800	2700*1325*2500	3.1
	900	1120	65	RVE1000-10-900	2700*1325*2500	3.3
	1000	1250	72	RVE1000-10-1000	2700*1325*2500	3.5
	1120	1400	81	RVE1000-10-1120	3000*1500*2542	3.7
	1250	1600	92	RVE1000-10-1250	3000*1500*2542	3.9
	1400	1800	104	RVE1000-10-1400	3000*1500*2542	4.1
	1500	1900	110	RVE1000-10-1500	3000*1500*2542	4.3
	1600	2000	115	RVE1000-10-1600	3000*1500*2542	4.4
	1800	2250	130	RVE1000-10-1800	3000*1500*2542	4.7
	2000	2500	144	RVE1000-10-2000	3000*1500*2542	4.9
	2240	2800	162	RVE1000-10-2240	3000*1500*2542	5.1
	2500	3150	182	RVE1000-10-2500	3000*1500*2542	5.4
	2650	3300	191	RVE1000-10-2650	3000*1500*2542	5.8
	2800	3500	202	RVE1000-10-2800	4500*1600*2731	8.5
	3150	4000	231	RVE1000-10-3150	4500*1600*2731	9.3
	3400	4250	245	RVE1000-10-3400	4500*1600*2731	9.8
	3600	4500	260	RVE1000-10-3600	4500*1600*2731	10.2
	4000	5000	289	RVE1000-10-4000	7200*1600*2895	14.5
	4500	5800	335	RVE1000-10-4500	7200*1600*2895	15.2

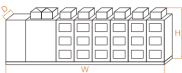
Schematic	drive power (kW)	Transformer capacity (kVA)	Output current (A)	Product number	Drive size (W*D*H mm)	gross weight (T)
	5000	6300	364	RVE1000-10-5000	11034*1700*2895	16.7
	5600	7000	404	RVE1000-10-5600	11034*1700*2895	18.5
	6300	8000	462	RVE1000-10-6300	11334*1700*2895	18.9
	7100	9000	520	RVE1000-10-7100	11334*1700*2895	20.2
	8000	10000	577	RVE1000-10-8000	11334*1700*2895	21.5
	9000	11200	650	RVE1000-10-9000	16550*1980*3438	41
	10000	12500	720	RVE1000-10-10000	16550*1980*3438	41
	11200	14000	810	RVE1000-10-11200	16550*1980*3438	41.8
	12500	16000	920	RVE1000-10-12500	16550*1980*3438	42.4

Note: For loads above 2650kW, a starter cabinet is required. For loads above 12500kW, please contact our company for model selection.

4. Installation and Connection

4.1 Acceptance

The correct acceptance procedure consists of the following parts:

- Check the delivery list to confirm that the equipment is complete
- Check for possible damage during transportation
- If there is any damage, claim compensation from the transportation company

Note: Depending on the size of the unit, wooden boards may be used to support the structure and unit during transportation, which must be removed during installation.

4.2 Transportation

Before transportation, you must have a correct estimate of the weight of the drive. Because the RVE1000 series medium voltage drive system varies with the user's specific application, the exact weight of the drive varies due to the different ratings and options of the drive. The size and weight of the system are indicated on the outside of the factory packaging and on the first page of the random drawing.

For easy transportation, the base of the cabinet has forklift holes designed for forklifts.

Two methods of transportation are recommended:

a: Lifting by crane or chain, it is recommended to use a sling, and the wire rope may cause some damage to the cabinet shell paint

b: Forklift



DANGER! ! Do not attempt to support the entire weight of the cabinet by the upper portion of the cabinet alone and do not lift any cabinet by the eyebolts.

Lifting by crane or chain - Use a sling to pass through the bottom hole and lift with a crane, as shown in Figure 3-1. The key is the length and strength of the sling. The sling must be long enough to ensure that the hook is at least 1.2m from the top of the cabinet to prevent deformation of the cabinet. If the distance is not enough, reinforcement must be used. The strength of the sling must be able to support the weight specified in the drawing.



When lifting with a sling, be sure to put the sling through the appropriate forklift hole. Try to make the lifting center coincide with the center of gravity of the drive.

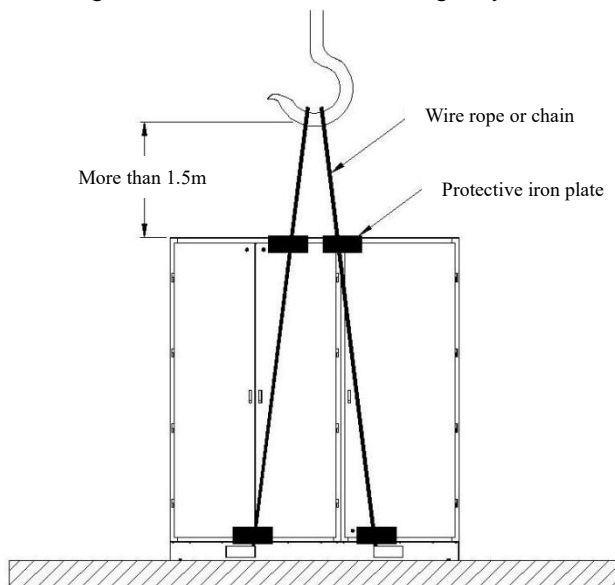

Figure 4-1 Lifting the drive with a sling or steel rope

Forklift - The forklift must be able to bear the corresponding weight, and the length of the forklift's shovel teeth must be at least longer than the width of the cabinet. When the drive cabinet is long, two forklifts can be used to work together.

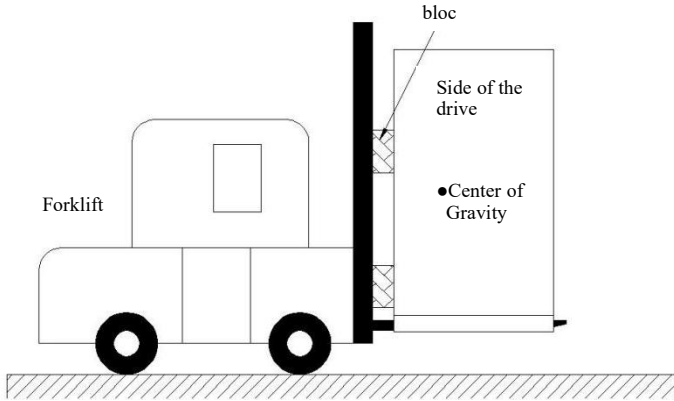

Figure 4-2 The correct way to use a forklift

Be careful not to let the forklift damage the cabinet surface. It is a good idea to use a piece of wood as a baffle at the corner of the fork teeth, as shown in Figure 4-2. The center of gravity of the drive cabinet is close to the middle of the front and rear panels.

4.3 Installation

4.3.1 Operating environment requirements

The efficiency of the RVE1000 series medium voltage drive is above 96% (the greater the power, the higher the efficiency), and the loss is basically converted into heat energy, so the heat dissipation of the medium voltage drive needs to be considered. The ambient temperature must be controlled below 40 degrees when the drive is operating normally.

4.3.2 Requirements for cabinet placement spacing

For the cabinet dimensions, external dimensions and bottom plate installation drawings of the drive, please refer to the relevant drawings in the engineering technical data. All cabinets should be installed according to the drawings, and sufficient space should be left outside to ensure air flow and maximum door opening, as well as the space required for maintenance. Provide access to the installation foundation (aisle spacing, etc.) and ensure that space is provided for the auxiliary equipment of the drive.

Minimum width of the channel around the medium voltage drive. As shown in Table 4-1.

Table 4-1 Channel width around the drive

	Front door gap	Gap between back door and wall
Gap distance	2m	1.5m

In order to ensure adequate heat dissipation, the distance between the top of the drive and the roof must comply with relevant national regulations. To further reduce the ambient temperature, users can install centralized ventilation ducts to pass the hot air through the centrifugal fan and directly lead it to the outdoors.

4.3.3 Installing the cooling fan

After the cabinet is in place, the fan should be installed next. Depending on the power, the number of fans that each drive may be equipped with may also be different. Please refer to the accompanying drawings for details. Each fan device has a cable with a plug connected to the corresponding wiring socket in the cabinet. When installing the fan, it should be plugged in first, the fan power line should be tightened and fixed with a cable tie, and finally the fan fixing screws should be tightened.

The air of the cooling unit cabinet and transformer cabinet is drawn in from the front door of the cabinet by the centrifugal fan installed on the top of the cabinet and enters the drive. The air outlet is on the top of the drive cabinet. The installation space must take into account air circulation. **The correct fan rotation direction is: the fan rotates clockwise when viewed from the bottom up. All fans have the same rotation direction when they leave the factory. If the fan's rotation direction is wrong during on-site commissioning, it can be corrected by changing the phase sequence of the fan power supply. Under the correct fan rotation direction, you can feel obvious air suction at the air inlet in front of the cabinet. The fan rotation direction can be judged to be correct according to the following conditions:**

- The fan blades rotate to the right when viewed from the outside;
- Looking upward from the inside of the drive, the fan rotates clockwise correctly;
- The green light of the phase sequence relay is on, and the fan rotates in the correct direction.

4.4 Wiring

All user power wiring terminals are concentrated in the transformer cabinet, and control wiring is concentrated in the control cabinet. Figure 4-3 is a typical system external interface diagram. The specific terminals may have slight differences due to different models or customer requirements.

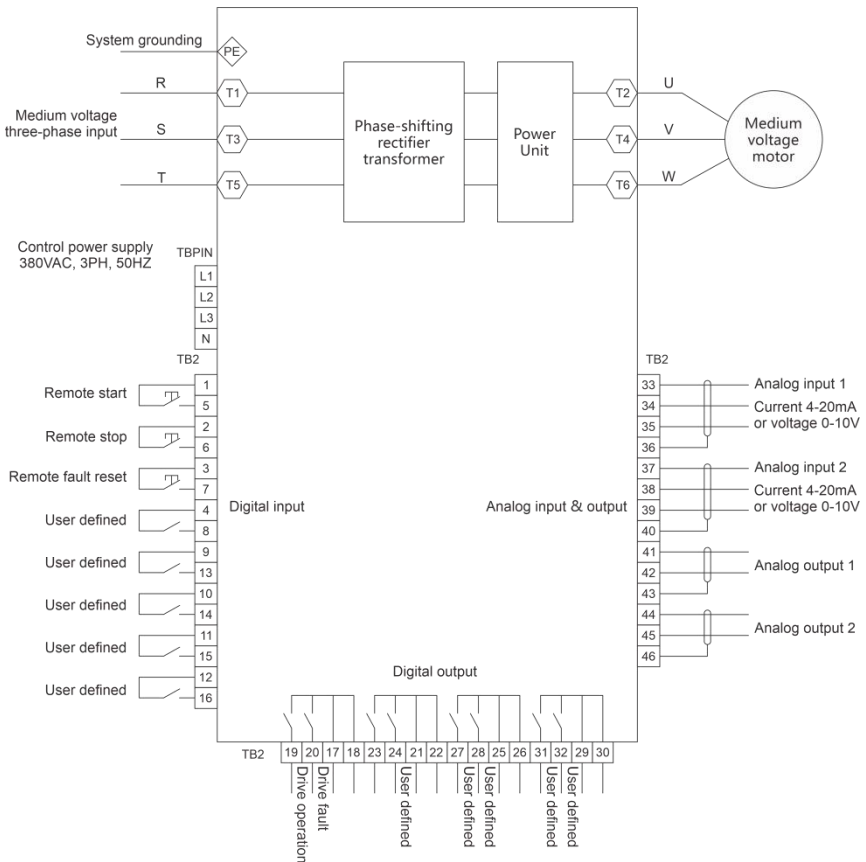

Figure 4-3 Typical system external interface diagram

Table 4-1 Power cable connection table

Terminal number	Wiring Definition	Remark
T1	Medium voltage input first phase R	All cables can be routed in from the top or bottom of the cabinet by simply removing the cover at the corresponding location.
T3	Medium voltage input second phase S	
T5	Medium voltage input third phase T	
T2	Medium voltage output first phase U	
T4	Medium voltage input second phase V	
T6	Medium voltage input third phase W	
PE	System grounding	
Terminal number	Wiring Definition	Remark
L1	Control power supply phase A	The control power supply is three-phase 380VAC and is connected to the terminal block TBPIN.
L2	Control power supply B phase	
L3	Control power supply C phase	
N	Control power neutral line	

There are three sets of $\pm 5\%$ voltage taps on the left side of the transformer to compensate for the power supply voltage. 0% taps are connected at the factory.

Table 4-2 Control cable terminal table

Terminal number	Terminal wiring definition number	Remark
TB2:1	Public terminal	DC24V, Source input
TB2:4	Remote start	
TB2:5	Remote stop	
TB2:6	Remote system reset	
TB2:12	User defined	
TB2:13	User defined	
TB2:14	User defined	
TB2:18, TB2:20	Drive operation	Relay output, normally open contact, contact capacity 3A, 250VAC
TB2:19, TB2:21	Drive alarm	
TB2:22, TB2:24	Drive fault	
TB2:23, TB2:25	User defined	
TB2:26, TB2:28	User defined	
TB2:33, TB2:34/TB2: 35	Analog input	4~20mA/0~10V
TB2:37, TB2:38/TB2: 39	Analog input	4~20mA/0~10V
TB2:41, TB2:42	Analog output	0~10V
TB2:44, TB2:45	Analog output	0~10V
TB2:47, TB2:48	Analog output	4~20mA
TB2:50, TB2:51	Analog output	4~20mA

5.Touchscreen

5.1 Introduction to the touch screen

The RVE1000 series medium voltage drive touch screen is an information interaction platform between the medium voltage drive and the user. It can help users to monitor the operation, fault monitoring, parameter adjustment, unit status monitoring, event query and other operations of the drive. The powerful database function can analyze and organize fault information, parameter information, and event information, thereby guiding the maintenance of the drive. Its operation interface is simple, intuitive, and has a large amount of information.

5.2 Touch screen operation

5.2.1 Touch screen main interface

After the touch screen is powered on, the default interface is the medium voltage touch screen main interface. The drive status bar is at the top, the software version number and RTC clock of the main control board are displayed on the left, and the current status, bypass mode and variable frequency/power frequency mode of the drive are displayed on the right; the middle part is the drive operation status, which displays the drive's operation data, control mode and current operation status; the right side displays the control command, and the control command can be issued by triggering the corresponding button after password login; the bottom is the sub-interface trigger button, and the corresponding sub-interface can be entered after clicking the button. There are two main interfaces with different background colors. The two main interfaces are switched every hour to achieve the function of screen saver. See Figure 5-1 and Figure 5-2.

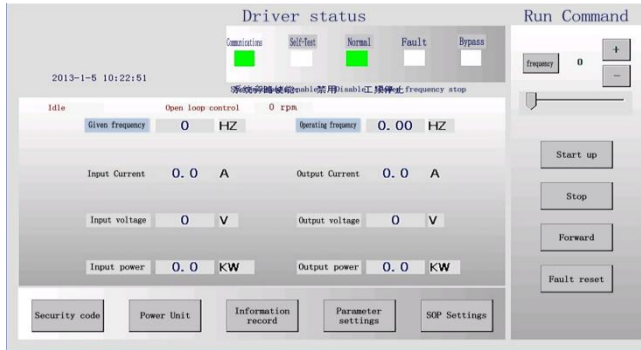

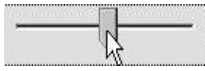

Figure 5-1 Touch screen main interface 1



Figure 5-2 Touch screen main interface 2

[Main interface] Key functions are shown in Table 5-1.

Table 5-1 drive main interface key functions

button	name	Function
	Frequency setting	Move the slider to change the current frequency value, click to change by step 1. Move to the left to decrease, and to the right to increase.
	frequency add	Add 0.5Hz to the current frequency.
	Frequency reduction	Subtract 0.5Hz from the current frequency.

button	name	Function
Frequency	Frequency setting	After the frequency is set, press this key to set.
Start up	Start button	Issue a start command to the drive.
Stop	Stop button	Issue a stop command to the drive.
Forward	Arrow key	Change the running direction of the drive. When in reverse state, it will display “forward”; when in forward state, it will display “reverse”.
Fault reset	Fault reset	Issue an drive fault reset command.
Security code	Password login	Enter the security code login sub-interface.
Power Unit	Power Unit	Enter the power unit sub-interface.
Information record	Information record	Enter the information record sub-interface.
parameter settings	Parameter settings	Enter the parameter setting sub-interface.
SOP Settings	SOP Settings	Enter the SOP setting sub-interface.

Description

Communication light: The touch screen displays green when the communication with the mainboard is normal, and red when it is abnormal.

Self-check light: Displays green during self-check and white in other states.

Normal light: Displays green when normal and white in other states.

Fault light: Displays yellow when alarming, red when faulty, and white in other states.

Bypass light: Displays yellow when the unit is bypassed, red when the whole machine is bypassed, and white in other states.

5.2.2 Touch screen password login interface

Password login has two types of operation permissions

Operator: Has the authority to browse system information and give operation commands and fault reset commands.

Administrator: In addition to operator permissions, also has the authority to set parameters, give reset commands, etc.

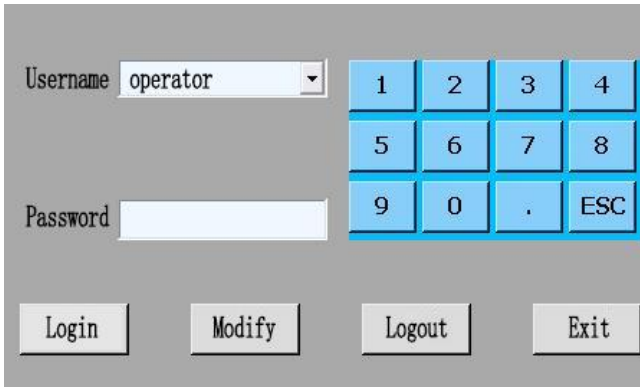

Figure 5-3 Touch screen password login interface

[Password Login] button functions are shown in Table 5-2.

Table 5-2 drive password login button functions

button	name	Function
Logout	Logout key	To cancel the current password, the current authority must be no less than that of the selected user.
Login	Login button	Confirm the password input and issue the login command. If the login is successful, return to the main interface.
Edit	Modifier Keys	Enter the password modification interface and you can modify the password only after logging in correctly.
Exit	Escape key	Exit the current interface and return to the main interface.

5.2.3 Touch screen password modification interface

Password modification is only effective when the corresponding password has been logged in and the drive is in the stopped state.

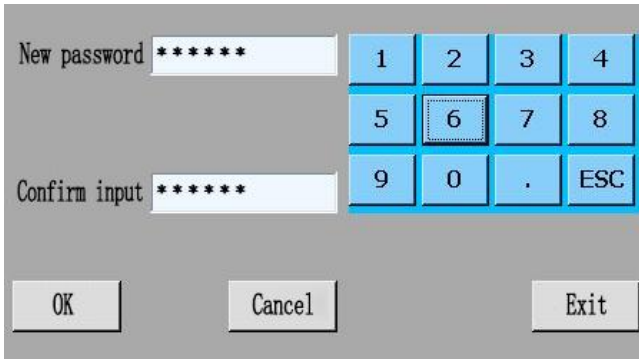

Figure 5-4 Touch screen password modification interface

[Password modification] button functions are shown in Table 5-3.

Table 5-3 drive password modification button functions

button	name	Function
OK	Confirm key	Confirm the new password input and issue a password change command. If the change is successful, return to the login interface.
Cancel	Cancel key	Cancel the password change operation.
Exit	Exit key	Exit the current interface and return to the security code login interface.

5.2.4 Touch screen power unit interface

The power unit interface monitors the bus voltage, radiator temperature, capacitor temperature, capacitor voltage, and fault status of each power unit.

According to the current fault status of the power unit, there will be a corresponding display on the interface. When an alarm occurs, it will display * in the corresponding fault state, ★ in the case of fault, and ● after the unit name in bypass. ↑ indicates an upstream fiber fault, and ↓ indicates a downstream fiber fault.

Unit	Start cur	Overvoltage	Overheat	Load cur	Wing status	Fiber optic	Radiator temperature	Capacitor temperature	Bus voltage	Capacitor 1 voltage	Capacitor 2 voltage	Capacitor 3 voltage
A1						↑	0	30	150	0	0	0
A2							30	30	982	322	320	322
A3							30	30	970	322	322	322
A4							36	30	970	322	322	322
A5						↑	0	0	150	0	0	0
B1							30	30	982	322	322	322
B2							30	30	970	322	322	322
B3							50	30	970	324	322	322
B4							30	30	970	322	322	322
B5							30	30	982	322	322	322
C1							30	30	982	322	322	322
C2							30	30	970	322	322	322
C3							30	30	970	322	322	322
C4							30	30	970	322	322	322
C5							30	35	970	322	322	322

Exit

Figure 5-5 Touch screen power unit interface

[Power Unit] The button functions are shown in Table 5-4.

Table 5-4 drive power unit key functions

button	name	Function
	Exit key	Exit the current interface and return to the security code login interface.

5.2.5 Information Record Interface

(1) Fault Record Interface

The fault record displays the most recent fault information, up to 255 items. Each fault information includes the fault number, fault level, fault name, input voltage, output current, current frequency, custom information, data, and fault time.

Fault log		Event log	IO status	Historical faults	Historical events							
Fault	Fault e.	Fault name	Input p.	Output p.	Current fr.	Custom in	Data	Fault time				
1	Fault	Input power failure	0	0	5	Input voltage	0	2012/12/07 13:16:45				
2	Fault	A1 uplink fiber	5980	0	5.5	Unit voltage	150	2012/12/07 11:58:10				
3	Fault	Bypass board uplink	5976	0	0	Communicati.	101	2012/12/07 11:53:18				
4	Fault	Phase A bypass	5970	0	5.5	Bypass board A	1024	2012/12/07 11:52:16				
5	Fault	A1 uplink fiber	5972	0	5.5	Unit voltage	150	2012/12/07 11:52:13				
6	Fault	Bypass board uplink	5987	0	0	Communicati.	101	2012/12/07 11:51:22				
7	Fault	Phase A bypass	5987	0	5.5	Bypass board A	1024	2012/12/07 11:51:08				
8	Fault	A1 uplink fiber	5981	0	5.5	Unit voltage	150	2012/12/07 11:51:05				
9	Fault	Phase A bypass	5978	0	5.5	Bypass board A	1024	2012/12/07 11:50:39				
10	Fault	A1 uplink fiber	5979	0	5.5	Unit voltage	150	2012/12/07 11:50:03				

A total of 10 faults!

Refresh Clear Export Exit

Figure 5-6 Touch screen fault record interface

Fault NO.	Fault Level	Fault name	Input voltage	Output current	Current frequency	Custom information	Data
1	Fault	A2 phase loss	5527	0	0	Unit voltage	322
2	Alarm	A2 phase loss	5510	0	0	Unit voltage	322
3	Fault	A2 voltage balancing	5516	0	0	Capacitor voltage maximum	C1 468
4	Alarm	Fault 340	2238	0	0	Undefined	0
5	Alarm	A5 voltage balancing	347	0	0	Capacitor voltage maximum	C1 322
6	Alarm	A2 voltage balancing	347	0	0	Undefined	C1 468
7	Alarm	Fault 340	2235	0	0	Undefined	0
8	Alarm	Fault 340	2211	0	0	Undefined	0
9	Alarm	Fault 340	2211	0	0	Undefined	0
10	Alarm	Fault 340	2207	0	0	Undefined	0
11	Fault	Input power failure	33	0	0	Input voltage	33
12	Alarm	B2 voltage balancing	5482	0	0	Capacitor voltage maximum	C1 322
13	Alarm	B2 voltage balancing	666	0	0	Capacitor voltage maximum	C1 322
14	Alarm	C3 upstream fiber	5504	0	0	Unit voltage	970
15	Fault	A3 overvoltage	5515	0	0	Unit voltage	1346
16	Fault	A phase bypass	5515	0	0	Bypass board A phase status	35846
17	Alarm	C4 voltage balancing	5507	0	0	Capacitor voltage maximum	C1 322
18	Alarm	C3 voltage balancing	5507	0	0	Capacitor voltage maximum	C1 322
19	Alarm	B4 voltage balancing	5506	0	0	Capacitor voltage maximum	C1 330
20	Fault	C1 phase loss	5514	0	0	Unit voltage	322
21	Alarm	A3 upstream fiber	5511	0	0	Unit voltage	0
22	Alarm	C1 phase loss	5527	0	0	Unit voltage	322
23	Fault	B3 overvoltage	5285	0	0	Unit voltage	1346
24	Fault	A2 overvoltage	5285	0	0	Unit voltage	1346
25	Alarm	C1 voltage balancing	349	0	0	Capacitor voltage maximum	C1 322
26	Alarm	B5 voltage balancing	349	0	0	Capacitor voltage maximum	C1 322
27	Alarm	B1 voltage balancing	0	0	0	Capacitor voltage maximum	C1 322

Figure 5-7 Touch screen fault export interface

[Fault Record] button functions are shown in Table 5-5.

Table 5-5 drive fault record button functions

button	name	Function
Refresh	Refresh key	Refresh the fault record.
Clear	Clear key	All current fault records can be cleared, but the fault information will be recorded in the historical fault database before clearing.
Export	Export Keys	Export the fault information to a USB flash drive in txt format. The file is named "F+current drive number+date" to distinguish the fault information of different drive for analysis and debugging. See Figure 5-6 for details.
Exit	Escape key	Exit the current interface and return to the main interface.

(2) Event record interface

The event record displays the most recent event information, up to 100 events can be recorded. Each event information includes event number, event level, event name, frequency or torque, information 1, information 2, and event time.

Fault log	Event log	IO status	Historical faults	Historical events			
Event	Event etc.	Event name	Frequency or torque	Message 1	Message 2	Event time	
1	Panel	System reset (fac.	Frequency: 0	Output current:2.7	(null)	2012/12/12 10:04:16	
2	None	Stop	Frequency: 0	Output current:4.9	(null)	2012/12/12 10:04:12	
3	None	Start	Frequency: 0	Output current:2.7	(null)	2012/12/12 10:04:12	
4	Panel	Operation freque.	Frequency: 0	Output current:2.7	(null)	2012/12/12 10:04:12	
5	Panel	Operation freque.	Frequency: 0	Output current:2.7	(null)	2012/12/12 10:03:01	
6	Panel	Operation freque.	Frequency: 0	Output current:2.7	(null)	2012/12/12 10:02:56	
7	None	Set parameters	Frequency: 0	Deceleration time T0	change into:15	2012/12/12 09:53:44	
8	None	Set parameters	Frequency: 0	Deceleration time T0	change into:20	2012/12/12 09:53:33	
9	None	Set parameters	Frequency: 0	Maximum frequency	change into:50	2012/12/12 09:53:19	
10	None	Set parameters	Frequency: 0	Maximum frequency	change into:60	2012/12/12 09:53:11	
11	None	Set parameters	Frequency: 0	Motor rated voltage	change into:10000	2012/12/12 09:52:55	
12	None	Set parameters	Frequency: 0	Motor rated voltage	change into:6000	2012/12/12 09:52:47	
13	Panel	System reset (fac.	Frequency: 0	Output current:2.7	(null)	2012/12/12 09:52:10	
14	None	Stop	Frequency: 0	Output current:5	(null)	2012/12/12 09:52:05	
15	None	Start	Frequency: 0	Output current:2.7	(null)	2012/12/12 09:52:05	
16	Panel	Operation freque.	Frequency: 0	Output current:2.7	(null)	2012/12/12 09:52:00	
17	Panel	System reset (fac.	Frequency: 0	Output current:2.7	(null)	2012/12/12 09:52:00	
18	None	Stop	Frequency: 0	Output current:5.1	(null)	2012/12/12 09:51:56	

Total 22 events!

Refresh Clear Export Exit

Figure 5-8 Touch screen event record interface

[Event Record] button functions are shown in Table 5-6.

Table 5-6 drive event record button functions

button	name	Function
Refresh	Refresh key	Refresh event log.
Clear	Clear key	All current event records can be cleared, but these event information will be recorded in the historical event database before clearing.
Export	Export Keys	Export the event information to a USB flash drive in txt format. The file is named "E+current drive number+date" to distinguish the event information of different drive for analysis and debugging.
Exit	Escape key	Exit the current interface and return to the main interface.

(3) IO status interface

Displays IO port status information. The definition of each IO port can be set in the "digital input" and "digital output" parameters. When the port status is a literal expression, "*" will be added after the definition name. No "*" indicates the opposite state to the definition. For example, the definition of digital output 12 is "medium

voltage power-on allowed", and the current actual state is that medium voltage input is not allowed, so there is no "*" displayed after it.

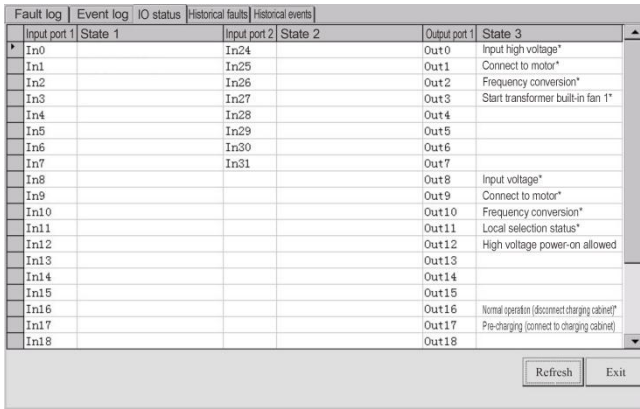

Figure 5-9 Touch screen IO status interface

[IO status] button functions are shown in Table 5-7.

Table 5-7 Drive IO status button functions

button	name	Function
Refresh	Refresh key	Refresh the current IO status.
Exit	Escape key	Exit the current interface and return to the main interface.

(4) Historical faults

The historical faults display the fault information that has occurred before. It will be automatically recorded every 20 hours or when the fault is cleared. It has an automatic identification function and will not record faults repeatedly. A maximum of 10,000 recent records can be stored.

The historical fault records are displayed in pages, with 200 records displayed per page. The page selection button can be used to make the touch screen display a specified page.

The fault records are arranged in order of occurrence time, with the most recent one at the front.

Event	Event etc.	Event name	Frequency or torque	Message 1	Message 2	Event time
1	Panel	System reset (fac.	Frequency: 0	Output current:2.7		2012/12/12 10:04:16
2	None	Stop	Frequency: 0	Output current:4.9		2012/12/12 10:04:12
3	None	Start	Frequency: 0	Output current:2.7		2012/12/12 10:04:12
4	Panel	Operation freq.	Frequency: 0	Output current:2.7		2012/12/12 10:04:12
5	Panel	Operation freq.	Frequency: 0	Output current:2.7		2012/12/12 10:03:01
6	Panel	Operation freq.	Frequency: 0	Output current:2.7		2012/12/12 10:02:56
7	None	Set parameters	Frequency: 0	Deceleration time T0	change into:15	2012/12/12 09:53:44
8	None	Set parameters	Frequency: 0	Deceleration time T0	change into:20	2012/12/12 09:53:33
9	None	Set parameters	Frequency: 0	Maximum frequency	change into:50	2012/12/12 09:53:19
10	None	Set parameters	Frequency: 0	Maximum frequency	change into:60	2012/12/12 09:53:11
11	None	Set parameters	Frequency: 0	Motor rated voltage	change into:10000	2012/12/12 09:52:55
12	None	Set parameters	Frequency: 0	Motor rated voltage	change into:6000	2012/12/12 09:52:47
13	Panel	System reset (fac.	Frequency: 0	Output current:2.7		2012/12/12 09:52:10
14	None	Stop	Frequency: 0	Output current:5		2012/12/12 09:52:05
15	None	Start	Frequency: 0	Output current:2.7		2012/12/12 09:52:05
16	Panel	Operation freq.	Frequency: 0	Output current:2.7		2012/12/12 09:52:05
17	Panel	System reset (fac.	Frequency: 0	Output current:2.7		2012/12/12 09:52:00
18	None	Stop	Frequency: 0	Output current:5.1		2012/12/12 09:51:56
19	None	Start	Frequency: 0	Output current:2.7		2012/12/12 09:51:56

Figure 5-10 Touch screen fault history interface

[Historical Fault] button functions are shown in Table 5-8.

Table 5-8 Drive Historical Fault Button Functions

button	name	Function
	previous page	View the previous page of historical fault information.
	next page	View the next page for historical fault information.
Goto	Jump to page	Use the drop-down box on the right to select the historical fault page you want to jump to.
	Refresh key	Store all current fault records in the historical fault database.
	Escape key	Exit the current interface and return to the main interface.

(5) Historical events

Historical events display information about events that have occurred before. They are automatically recorded every 20 hours or when the event is cleared. They have an automatic recognition function and will not record events repeatedly. A maximum of 10,000 recent records can be stored.

Historical event records are displayed in pages, with 200 records displayed per page. The touch screen can display a specified page by clicking the page selection button. Event records are arranged in order of occurrence time, with the most recent event at the front.

Event	Event etc.	Event name	Frequency or torque	Message 1	Message 2	Event time
1	Panel	Fault clear (panel)	Frequency: 0	Output current:0		2012/12/12 10:04:16
2	None	Super administrat.	Frequency: 0	Output current:0		2012/12/12 10:04:12
3	None	Automatic bypass.	Frequency: 0	Output current:0		2012/12/12 10:04:12
4	None	Set parameters	Frequency: 0	Index number:300	change into:1	2012/12/12 10:04:12
5	None	Set parameters	Frequency: 0	Index number:73	change into:0	2012/12/12 10:03:01
6	None	Manual bypass m.	Frequency: 0	Output current:0		2012/12/12 10:02:56
7	None	Automatic bypass.	Frequency: 0	Output current:0		2012/12/12 09:53:44
8	None	Set parameters	Frequency: 0	Index number:77	change into:0	2012/12/12 09:53:33
9	None	Set parameters	Frequency: 0	Index number:76	change into:0	2012/12/12 09:53:19
10	None	Set parameters	Frequency: 0	Index number:75	change into:19	2012/12/12 09:53:11
11	None	Set parameters	Frequency: 0	Index number:74	change into:18	2012/12/12 09:52:55
12	None	Set parameters	Frequency: 0	Index number:73	change into:17	2012/12/12 09:52:47
13	None	Set parameters	Frequency: 0	Index number:72	change into:5	2012/12/12 09:52:10
14	None	Set parameters	Frequency: 0	Index number:251	change into:0	2012/12/12 09:52:05
15	None	Set parameters	Frequency: 0	Index number:250	change into:0	2012/12/12 09:52:05
16	None	Set parameters	Frequency: 0	Index number:423	change into:0	2012/12/12 09:52:05
17	Panel	System reset (pan.	Frequency: 0	Output current:0		2012/12/12 09:52:00
18	None	Super administrat.	Frequency: 0	Output current:0		2012/12/12 09:51:56
19	Terminals	Select frequency.	Frequency: 0	Output current:0		2012/12/12 09:51:56

Figure 5-11 Touch screen historical event interface

[Historical Event] button functions are shown in Table 5-9.

Table 5-9 Drive Historical Event button functions

button	name	Function
	previous page	View the previous page for historical event information.
	next page	See the next page for historical event information.
Goto	Jump to page	Use the drop-down box on the right to select the historical event page you want to jump to.
	Escape key	Exit the current interface and return to the main interface.

5.2.6 Touch screen parameter setting interface

The parameter setting interface includes parameters, system settings, other settings, and backup parameters.

(1) Parameter browsing interface:

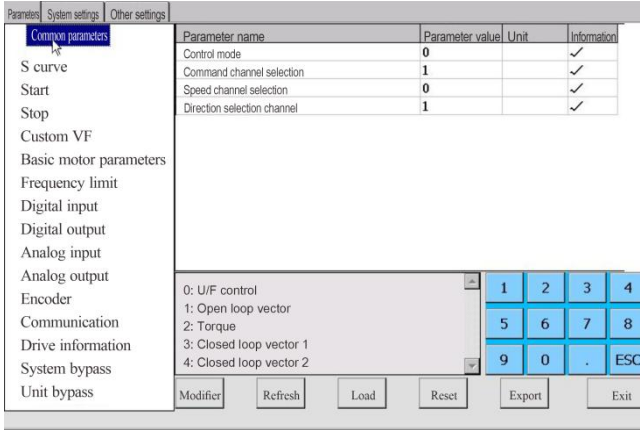

Figure 5-12 Touch screen parameter browsing interface

(2) Parameter setting interface

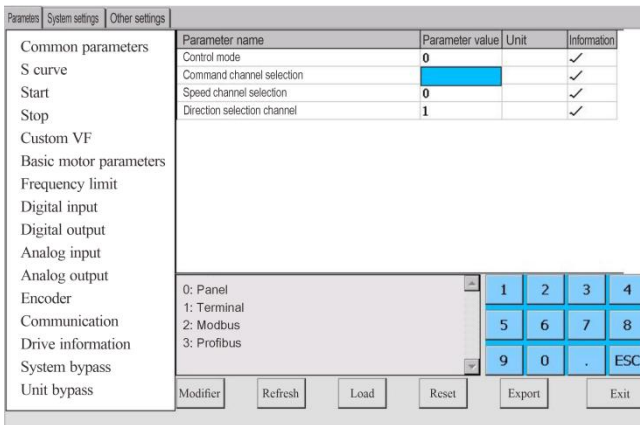

Figure 5-13 Touch screen parameter setting interface (with numeric keyboard)

[System Parameters] See Table 5-10 for key functions.

Table 5-10 Drive system parameter key functions

button	name	Function
Modifier	Modifier Keys	Confirm parameter modification. Parameters can only be modified in the stopped state.
Refresh	Refresh key	Re-read the parameters that were not read successfully in this class.
Load	Load button	Re-read all parameters of this class.
Reset	Reset button	Reset parameters to default values. Parameters can only be reset in the stopped state.
Export	Export Key	Export the parameters to a USB flash drive.
Exit	Escape key	Exit the current interface and return to the main interface.

Parameter modification instructions: When the system is stopped, click the parameter value to be modified, enter the expected parameter value on the numeric keypad according to the range and instructions below, and click the "Modify" button below to confirm the modification. After the parameter is modified, the value of the parameter will be re-read. If the reading is unsuccessful, it can be refreshed.

Parameter export instructions: The parameters are exported in database format. The conversion software provided by our company is required to convert the database into txt format.

(3) System setting interface

Displays the system's acquisition board zero value, acquisition board version number, IO expansion board version number, touch screen software version number, RTC clock, number of operations, energy consumption, operation time, variable frequency operation time, power frequency operation time and other information.

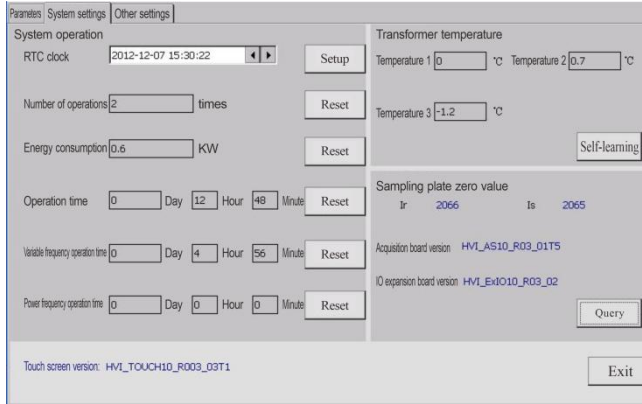

Figure 5-14 Touch screen system setting interface

The functions of the [System Setting] buttons are shown in Table 5-11.

Table 5-11 Drive system setting button functions

button	name	Function
Setup	Setup Keys	Set the system RTC clock.
Reset	Reset button	Clear the corresponding system value to zero.
Self-learning	Self-learning	Self-learning Ir, Is;
Query	Query	Read the acquisition board and IO expansion board software version number;
Exit	Escape key	Exit the current interface and return to the main interface.

RTC clock setting instructions: The system clock is divided into 6 segments: year, month, day, hour, minute, and second. Move the cursor to the segment you want to set, press the up and down keys "◀ ▶" on the right to modify, and press the set key to confirm after the setting is completed.

(4) Other settings

Set the drive number, cascade number, baud rate, voltage direction, hidden backup parameters, and display level. These are already set at the factory and most of them do not need to be used. If you want to know more, you can make corresponding settings.

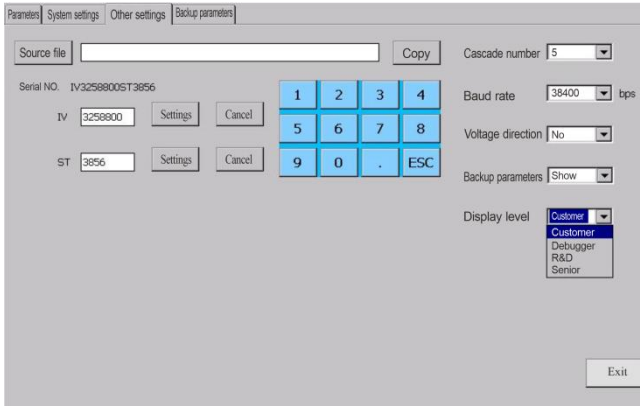

Figure 5-15 Touch screen other settings interface

[Other settings] button functions are shown in Table 5-12.

Table 5-12 Drive other settings button functions

button	name	Function
Source file	File Selection	When updating the parameter database, click this button to select the source file address (usually Para in the USB flash drive).
Copy	Copy key	Click this button to copy the parameter database to your local computer.
Settings	Setting Key	Set the drive number.
Cancel	Cancel key	Cancel the numbering setting.

button	name	Function
Number of cascades	Cascade number setting	Select the number of cascades from the drop-down box on the right. It is set at the factory and should not be modified.
Baud rate	Serial port baud rate setting	Set the communication rate between the touch screen and the mainboard. Please do not modify it. If the setting is incorrect, the touch screen will not work properly.
Voltage direction	Voltage direction setting	Select whether to display the input and output voltage phase sequence on the main interface. It is not displayed by default.
Backup parameters	Backup parameter hiding	Select whether to hide the backup parameter page. It is hidden by default.
Display level	Display level selection	Select the display level of parameters and backup parameters from the drop-down box on the right. The parameters will display different contents according to the different levels. The default is customer level.
Exit	Escape key	Exit the current interface and return to the main interface.

(5) Backup parameters

View the drive parameter backup information and give the backup command. To view this page, you need to set "Parameter backup" to "Display" in the "Other settings interface".

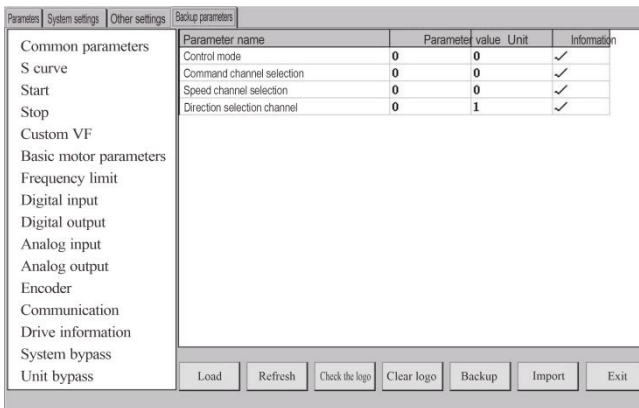

Figure 5-16 Touch screen backup parameter interface

The [Backup parameter] button function is shown in Table 5-13.

Table 5-13 Drive backup parameter button function

button	name	Function
Refresh	Refresh key	Reread the parameters that were not read successfully in this class.
Loading	Load button	Re-read all parameters of this class.
Check the logo	Check backup flag	Check the backup flag to see if the parameters are backed up.
Clear logo	Clear backup flag	Clear the backup flag.
Backup	Backup parameters	Back up the current parameter values.
Import	Setting key	Set the drive number.
Exit	Escape key	Exit the current interface and return to the main interface.

5.2.7 SOP setting interface

The SOP setting interface displays the shielding status of all drive faults. "Undefined" means shielding the fault; "Alarm" means the drive alarms when the fault occurs; "Fault" means the drive fails when the fault occurs; "Alarm & Fault" means when the fault occurs, an alarm occurs within a certain range and a fault occurs when the range is exceeded. A total of 512 faults are defined, which are displayed in 16 pages, with 32 faults displayed on each page.

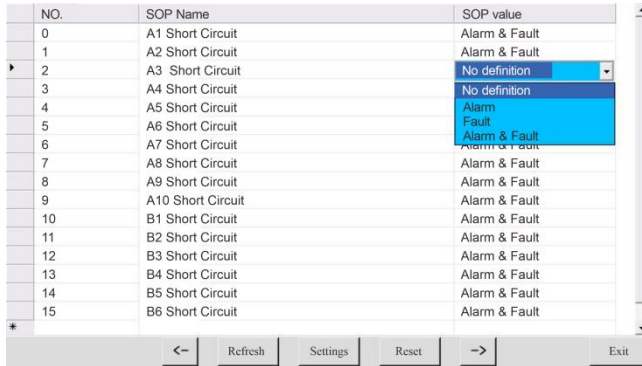







Figure 5-17 Touch screen SOP setting interface

The [SOP setting] button functions are shown in Table 5-14.

Table 5-14 Drive SOP setting button functions

button	name	Function
	previous page	Displays the SOP value of the previous page.
	Refresh	Refresh the current SOP value.
	Settings	Set the SOP definition value.
	Reset button	The SOP value for resetting a fault is the default value.
	next page	Displays the SOP value for the next page.
	Escape key	Exit the current interface and return to the main interface.

6. Function parameter table

This chapter lists the drive parameters and related information as a general list for customers to use for reference. If you use advanced applications, please contact our company's technical service department.

6.1 Function group classification

Parameters are classified by group. The function group classification is shown in Table 6-1.

No.	Function Group Name
1	Basic Parameters
2	Adjust Parameters
3	Motor Parameters
4	Frequency Parameters
5	I/O Parameters
6	Expand Parameters
7	Display Parameters
8	Unit Parameters

6.2 Function List and Description

6.2.1 Basic Parameters

Among the common parameters, set the control mode, operation mode, and channel selection of the drive.

Name	Content	Predetermined area	unit	Factory settings	Remark
Control Mode	0: V/F control 1: Open loop vector control 2: Torque control 3: Closed loop vector control	0~4	×	0	
Command channel selection	0: Panel 1: Terminal 2: Modbus 3: Profibus	0~3	×	0	

Name	Content	Predetermined area	unit	Factory settings	Remark
Frequency channel selection	0: Panel target speed 1: Digital multi-speed given target speed 2: Analog multi-speed given target speed 3: Analog 1 given target speed 4: Analog 1 given current speed 5: Analog 2 given target speed 6: Analog 2 given current speed 7: Modbus given target speed 8: Function given target speed 9: Analog 3 given target speed 10: Analog 3 given current speed 11: Analog 4 given target speed 12: Analog 4 given current speed 13: Analog 5 given target speed 14: Analog 5 given current speed 15: Analog 6 given target speed 16: Analog 6 given current speed 17: Analog 7 given target speed 18: Analog 7 given current speed 19: Analog 8 given target speed 20: Analog 8 given current speed 21: Profibus given	0~21	×	0	
Direction channel selection	0: Panel 1: Terminal 2: Modbus 3: Profibus	0~3	×	0	

6.2.2 Adjust Parameters

6.2.2.1 S Curve Parameters

In S Curve Parameters, set the acceleration and deceleration time of the S curve.

Name	Content	Predetermined area	unit	Factory settings	Remark
Acceleration time T0	Set the acceleration time from 0 to 50 Hz	2~655.35	s	12	
Deceleration time T0	Set the deceleration time from 50Hz to 0	2~655.35	s	18	

6.2.2.2 Start Parameters

In the Start Parameters, set the drive start mode parameters.

Name	Content	Predetermined area	unit	Factory settings	Remark
Startup mode selection	0: Normal start 1: Restart after DC braking 2: Speed tracking start	0~2	×	0	

6.2.2.3 Stop Parameters

In the stop parameters, set the relevant parameters when the drive stops.

Name	Content	Predetermined area	unit	Factory settings	Remark
Parking mode selection	0: Inertia stop 1: Deceleration stop 2: Deceleration + DC braking	0~2	×	0	

6.2.2.4 Custom V/F Parameters

Name	Content	Predetermined area	unit	Factory settings	Remark
V/F curve type selection	V/F curve type: 0: V/F 1~9: $V^{(1.n)}/F$ 10: V^2/F 11: User-defined curve	0~11	×	0	V/F curve type selection
Low speed compensation	Set the voltage compensation value of the drive at low frequency	0~200	%	100	Low speed compensation%1 dot
Low speed compensation maximum frequency	Set the maximum frequency value of the drive low speed compensation	0~50	Hz	10	Low speed compensation maximum frequency Hz2 dot
V/F modulation ratio	It is recommended not to exceed 1.2	0.1~2	×	1	

6.2.3 Motor Parameters

6.2.3.1 Common Parameters

In Common Parameters, set the motor nameplate value.

Name	Content	Predetermined area	unit	Factory settings	Remark
Motor rated power	Set the rated power of the motor	0~6553.5	kW	350	
Motor rated current	Set the rated current of the motor	0~6553.5	A	39	
Motor rated frequency	Set the rated frequency of the motor	0~60	Hz	50	
Motor rated speed	Set the rated speed of the motor	0~65535	rpm	1483	
Motor rated voltage	Set the rated voltage of the motor	0~65535	V	6000	
Motor pole pair number	Set the number of pole pairs of the motor	1~8	p	2	
Motor phase sequence	Set the phase sequence of the motor	0~1	×	0	The default direction of the motor can be set

6.2.4 Frequency Control Parameters

6.2.4.1 Frequency Limit Parameters

In the frequency limit parameters, set the maximum frequency and minimum frequency.

Name	Content	Predetermined area	unit	Factory settings	Remark
Maximum frequency	Set the maximum operating frequency of the Drive	0~60	Hz	50	
Minimum frequency	Set the minimum operating frequency of the Drive	0~60	Hz	5	

6.2.4.2 Skip Frequency Parameters

In the skip frequency parameters, set the skip frequency and skip width.

Name	Content	Predetermined area	unit	Factory settings	Remark
Frequency hopping speed 1	Set hop frequency 1	0~60	Hz	0	Frequency hopping speed Hz2dot
Frequency hopping speed 2	Set hop frequency 2	0~60	Hz	0	Frequency hopping speed Hz2dot
Frequency hopping speed 3	Set hop frequency 3	0~60	Hz	0	Frequency hopping speed Hz2dot
Frequency hopping width	Set hop bandwidth	0~5	Hz	0	Frequency hopping speed Hz2dot

6.2.4.3 Digital Multi-velocity Parameters

In the digital multi-velocity parameters, set the frequency value corresponding to each speed.

Name	Content	Predetermined area	unit	Factory settings	Remark
Digital multi-speed 0	Set the frequency corresponding to speed 0	0~60	Hz	5	
Digital multi-speed 1	Set the frequency corresponding to speed 1	0~60	Hz	5	
Digital multi-speed 2	Set the frequency corresponding to speed 2	0~60	Hz	10	
Digital multi-speed 3	Set the frequency corresponding to speed 3	0~60	Hz	20	
Digital multi-speed 4	Set the frequency corresponding to speed 4	0~60	Hz	30	
Digital multi-speed 5	Set the frequency corresponding to speed 5	0~60	Hz	40	
Digital multi-speed 6	Set the frequency corresponding to speed 6	0~60	Hz	50	
Digital multi-speed 7	Set the frequency corresponding to speed 7	0~60	Hz	50	
Digital multi-speed 8	Set the frequency corresponding to speed 8	0~60	Hz	5	

Name	Content	Predetermined area	unit	Factory settings	Remark
Digital multi-speed 9	Set the frequency corresponding to speed 9	0~60	Hz	5	
Digital multi-speed 10	Set the frequency corresponding to speed 10	0~60	Hz	10	
Digital multi-speed 11	Set the frequency corresponding to speed 11	0~60	Hz	15	
Digital multi-speed 12	Set the frequency corresponding to speed 12	0~60	Hz	20	
Digital multi-speed 13	Set the frequency corresponding to speed 13	0~60	Hz	30	
Digital multi-speed 14	Set the frequency corresponding to speed 14	0~60	Hz	40	
Digital multi-speed 15	Set the frequency corresponding to speed 15	0~60	Hz	50	

6.2.5 Terminal Function Parameters

6.2.5.1 Digital Input Parameters

In the digital input parameters, set the function of each input port.

Name	Content	Predetermined area	unit	Factory settings
Digital input 0 function	<p>0: No function; >0 has function</p> <p>1: Start (level signal) is 1 valid, default is 0</p> <p>2: Stop (level signal) is 0 valid, default is 0</p> <p>3: Local system reset is 1 valid, default is 0</p> <p>4: Local emergency stop is 0 valid, default is 1</p> <p>5: Soft start (pulse signal↑)</p> <p>6: Cooling fan operation is 1 valid, default is 1</p> <p>7: UPS power supply is normal is 1 valid, default is 1</p> <p>8: Cabinet door open is 0 valid, default is 1</p> <p>9: Transformer to 130°C is 0, default is 1</p> <p>10: Transformer to 150°C is 0, default is 1</p> <p>11: Cabinet top fan fault is 1, default is 0</p> <p>12: Unit fan thermal relay trip is 1, default is 0</p> <p>13: External ready signal, 1 valid, default is 1</p> <p>14: External fault signal, 0 is fault, 1 is normal, default is 1</p> <p>15: External fault signal, 1 is fault, 0 is normal, default is 1</p>	0~128	×	3

Name	Content	Predetermined area	unit	Factory settings
	<p>16: medium voltage emergency disconnect input (total input), 1 is valid, default is 0</p> <p>17: System bypass manual/automatic selection, 0 is manual, 1 is automatic, no definition, no modification</p> <p>18: Power frequency cuts to variable frequency (pulse signal↑), no definition, no modification</p> <p>19: Variable frequency cuts to power frequency (pulse signal↑), no definition, no modification</p> <p>20: Direction, 1 forward, 0 reverse, no definition, no modification</p> <p>21: Multi-speed terminal 1 is 1 valid, default is 0</p> <p>22: Multi-speed terminal 2 is 1 valid, default is 0</p> <p>23: Multi-speed terminal 3 is 1 valid, default is 0</p> <p>24: Multi-speed terminal 4 is 1 valid, default is 0</p> <p>25: Multi-speed terminal 5 is 1 valid, default is 0</p> <p>26: Multi-speed terminal 6 is 1 valid, default is 0</p> <p>27: Multi-speed terminal 7 is 1 valid, default is 0</p> <p>28: Multi-speed terminal 8 is valid when 1, and the default value is 0</p> <p>29: User input 1 is valid when 1, and the default value is 0</p> <p>30: User input 2 is valid when 1, and the default value is 0</p> <p>31: User input 3 is valid when 1, and the default value is 0</p> <p>32: User input 4 is valid when 1, and the default value is 0</p> <p>33: User input 5 is valid when 1, and the default value is 0</p> <p>34: User input 6 is valid when 1, and the default value is 0</p> <p>35: User input 7 is valid when 1, and the default value is 0</p> <p>36: User input 8 is valid when 1, and the default value is 0</p> <p>37: Cut off water pump 1 is valid when 1, and the default value is 0</p>			

Name	Content	Predetermined area	unit	Factory settings
	<p>38: Cut off water pump 2 is valid when 1, and the default value is 0</p> <p>39: Cut off water pump 3 is valid when 1, and the default value is 0</p> <p>40: Cut off water pump 4 is valid when 1, and the default value is 0</p> <p>41: Water pump emergency stop</p> <p>42: Power frequency start (KM3 closed) (pulse signal↑)</p> <p>43: Power frequency stop (KM3 disconnected) (pulse signal↑)</p> <p>44: Power frequency conversion mode, 0 is frequency conversion mode, 1 is power frequency mode, default is 0</p> <p>45: One-to-two motor selection, 0 is KM1~KM3, 1 is KM4~KM6, default is 0</p> <p>46: Backup motor power frequency start (pulse signal↑)</p> <p>47: Backup motor power frequency stop (pulse signal↑)</p> <p>48: Remote start (pulse signal↑)</p> <p>49: Remote stop (pulse signal↑)</p> <p>50: Remote system reset is 1 valid, default is 0</p> <p>51: Remote emergency stop is 0 valid, default is 1</p> <p>52: Vacuum contactor K1 feedback is 0 closed, 1 is open</p> <p>53: Vacuum contactor K2 feedback is 0 closed, 1 is open</p> <p>54: Vacuum contactor K3 feedback is 0 closed, 1 is open</p> <p>55: Vacuum contactor K4 feedback is 0 closed, 1 is open</p> <p>56: Vacuum contactor K5 feedback is 0 closed, 1 is open</p> <p>57: Vacuum contactor K6 feedback is 0 closed, 1 is disconnected</p> <p>58: One-to-four first power frequency contactor feedback is 0 closed, 1 is disconnected</p> <p>59: One-to-four second power frequency contactor feedback is 0 closed, 1 is disconnected</p> <p>60: One-to-four third power frequency contactor feedback is 0 closed, 1 is disconnected</p>			

Name	Content	Predetermined area	unit	Factory settings
	61: One-to-four fourth power frequency contactor feedback is 0 closed, 1 is disconnected 62: Automatic/manual control selection for internal mixer, 1 is automatic 63: Backup power supply, 0 is backup power supply, 1 is external 380V power supply 64: Charging cabinet feedback, 0 is charging completed, 1 is charging 65: Manual knife switch motor 1 feedback, 1 is valid, default is 0 66: Manual knife switch motor 2 feedback, 1 is valid, default is 0 67: Local remote control, 1 remote control, 0 local control, default is 0 68~128: Reserved			
Digital input 1 function	Same as digital input 0 function definition	0~128	×	8
Digital input 2 function	Same as digital input 0 function definition	0~128	×	7
Digital input 3 function	Same as digital input 0 function definition	0~128	×	6
Digital input 4 function	Same as digital input 0 function definition	0~128	×	11
Digital input 5 function	Same as digital input 0 function definition	0~128	×	4
Digital input 6 function	Same as digital input 0 function definition	0~128	×	48
Digital input 7 function	Same as digital input 0 function definition	0~128	×	49
Digital input 8 function	Same as digital input 0 function definition	0~128	×	50
Digital input 9 function	Same as digital input 0 function definition	0~128	×	0
Digital input 10 function	Same as digital input 0 function definition	0~128	×	0
Digital input 11 function	Same as digital input 0 function definition	0~128	×	0
Digital input 12 function	Same as digital input 0 function definition	0~128	×	0
Digital input 13 function	Same as digital input 0 function definition	0~128	×	0

Name	Content	Predetermined area	unit	Factory settings
Digital input 14 function	Same as digital input 0 function definition	0~128	×	0
Digital input 15 function	Same as digital input 0 function definition	0~128	×	0
Digital input 16 function	Same as digital input 0 function definition	0~128	×	0
Digital input 17 function	Same as digital input 0 function definition	0~128	×	0
Digital input 18 function	Same as digital input 0 function definition	0~128	×	0
Digital input 19 function	Same as digital input 0 function definition	0~128	×	0
Digital input 20 function	Same as digital input 0 function definition	0~128	×	0
Digital input 21 function	Same as digital input 0 function definition	0~128	×	0
Digital input 22 function	Same as digital input 0 function definition	0~128	×	0
Digital input 23 function	Same as digital input 0 function definition	0~128	×	0

6.2.5.2 Digital Output Parameters

In the digital output parameters, set the function and related parameters of each output port.

Name	Content	Predetermined area	unit	Factory settings
Digital output 0 function	<p>0: No function; >0 has function</p> <p>1: Output 1 when ready to run, otherwise output 0</p> <p>2: Output 1 for fault, otherwise output 0</p> <p>3: Output 1 for operation, otherwise output 0</p> <p>4: Output 1 for alarm, otherwise output 0</p> <p>5: Connect to medium voltage on the input side of the drive, 0 to cut off input, 1 to connect to input</p> <p>6: Cut in power frequency, 1 to cut in power frequency, 0 for frequency conversion</p> <p>7: Cut off charging cabinet, 1 to cut off charging resistor</p> <p>8: Connect charging cabinet, 1 to connect charging resistor</p> <p>9: Connect to the motor on the output side</p>	0~128	×	3

Name	Content	Predetermined area	unit	Factory settings
	of the drive, 0 to cut off motor, 1 to connect to motor 10: Frequency arrival, 1 11: Frequency conversion working state, 1 12: Power frequency working state, 1 13: Upper limit frequency arrival, 1 14: Lower limit frequency arrival, 1 15: Unit bypass state, 1 16: medium voltage switch emergency disconnection, 1 17: Reserved 18: Reserved 19: One-to-four first variable frequency connection, 1 is variable frequency connection 20: One-to-four first power frequency connection, 1 is power frequency connection 21: One-to-four second variable frequency connection, 1 is variable frequency connection 22: One-to-four second power frequency connection, 1 is power frequency connection 23: One-to-four third variable frequency connection, 1 is variable frequency connection 24: One-to-four third power frequency connection, 1 is power frequency connection 25: One-to-four fourth variable frequency connection, 1 is variable frequency connection 26: One-to-four fourth power frequency connection, 1 is power frequency connection 27: User-defined output 1, 1 is valid, default is 0 28: User-defined output 2, 1 is valid, default is 0 29: User-defined output 3, 1 is valid, default is 0 30: User-defined output 4, 1 is valid, default is 0 31: User-defined output 5, 1 is valid, default is 0 32: User defined output 6, 1 is valid, default is 0 33: User defined output 7, 1 is valid, default is 0 34: User defined output 8, 1 is valid, default			

Name	Content	Predetermined area	unit	Factory settings
	<p>is 0</p> <p>35: Transformer built-in fan control 1, 1 is started, default is 0</p> <p>36: Transformer built-in fan control 2, 1 is started, default is 0</p> <p>37: Transformer built-in fan control 3, 1 is started, default is 0</p> <p>38: Dehumidifier 1, 1 is started, default is 0</p> <p>39: Dehumidifier 2, 1 is started, default is 0</p> <p>40: Dehumidifier 3, 1 is started, default is 0</p> <p>41: drive input is connected to the network side 2, 0 is cut off input, 1 is connected to input</p> <p>42: drive output is connected to motor 2, 0 is cut off motor, 1 is connected to motor</p> <p>43: Power frequency is cut into motor 2, 1 is cut into power frequency, 0 is variable frequency</p> <p>44: drive fan control, 1 start, default is 0</p> <p>45: medium voltage power-on is allowed, 1 is power-on is allowed, default is 0</p> <p>46: System status 1 detection, default is 0</p> <p>47: System status 2 detection, default is 0</p> <p>48: System status 3 detection, default is 0</p> <p>49: System status 4 detection, default is 0</p> <p>50: Connect K1 (grid connected to drive), pulse signal</p> <p>51: Disconnect K1 (grid disconnects drive), pulse signal</p> <p>52: Connect K2 (grid connected to drive), pulse signal</p> <p>53: Disconnect K2 (grid disconnects drive), pulse signal</p> <p>54: Connect K3 (grid connected to drive), pulse signal</p> <p>55: Disconnect K3 (grid disconnects drive), pulse signal</p> <p>56: Connect K4 (grid connected to drive), pulse signal</p> <p>57: Disconnect K4 (grid disconnects drive), pulse signal</p> <p>58: Connect K5 (grid connected to drive), pulse signal</p> <p>59: Disconnect K5 (grid disconnects drive), pulse signal</p> <p>60: Connect K6 (grid connected to drive), pulse signal</p>			

Name	Content	Predetermined area	unit	Factory settings
	61: Disconnect K6 (grid disconnects drive), pulse signal 62: Local remote selection status, 1 for remote, 0 for local; default output 0 63: Reserved, default output 0 64: Reserved, default output 0 65: drive fan control delay 5s, 1 start, default 0 66: Drive fan control delay 10s, 1 start, default 0 67~128: Reserved			
Digital output 1 function	Same as digital output 0 function definition	0~128	×	9
Digital output 2 function	Same as digital output 0 function definition	0~128	×	6
Digital output 3 function	Same as digital output 0 function definition	0~128	×	3
Digital output 4 function	Same as digital output 0 function definition	0~128	×	0
Digital output 5 function	Same as digital output 0 function definition	0~128	×	0
Digital output 6 function	Same as digital output 0 function definition	0~128	×	0
Digital output 7 function	Same as digital output 0 function definition	0~128	×	3
Digital output 8 function	Same as digital output 0 function definition	0~128	×	0
Digital output 9 function	Same as digital output 0 function definition 0~128	0~128	×	0
Digital output 10 function	Same as digital output 0 function definition	0~128	×	0
Digital output 11 function	Same as digital output 0 function definition	0~128	×	0
Digital output 12 function	Same as digital output 0 function definition	0~128	×	0

Name	Content	Predetermined area	unit	Factory settings
Digital output 13 function	Same as digital output 0 function definition	0~128	×	0
Digital output 14 function	Same as digital output 0 function definition	0~128	×	0
Digital output 15 function	Same as digital output 0 function definition	0~128	×	0

6.2.5.3 Analog Input Parameters

Name	Content	Predetermined area	unit	Factory settings	Remark
Analog input 1 to 8 types	0: 0~10V 1: -10~10V 2: 1~10V (with 0~10V) 3: 0~20mA 4: 4~20mA 5: 1~10V (with -10~10V)	0~5	×	0	
Analog input 1 to 8 functions	0: No function 1: Target speed input 2: Current speed input 3: Torque input 4: Weighing compensation input	0~4	×	0	
Analog input 1 to 8 bias	The bias effect is: Analog value - (bias parameter - 10V)	0~65.535	×	5.236	
Analog input 1 to 8 gain	The gain effect is: gain*(analog value - (bias parameter - 10V))	0~6553.5	%	238.6	

6.2.5.4 Analog Output Parameters

Name	Content	Predetermined area	unit	Factory settings	Remark
Analog output 1~9 function	0: Undefined function 1: U-phase instantaneous current 2: V-phase instantaneous current 3: W-phase instantaneous current 6: Current frequency 7: Current feedback speed	0~79	×	7	

Name	Content	Predetermined area	unit	Factory settings	Remark
	(encoder required) 43: Target frequency 48: 0 49: Full-scale output (10V or 20mA) 59: Output current effective value 62: Input power 63: Output power 64: sin(x) 65: sin(x+120°) 66: sin(x+240°) 68: Ur instantaneous value 69: Us instantaneous value 70: Ut instantaneous value 71: Uu instantaneous value 72: Uv instantaneous value 73: Uw instantaneous value 74: Target torque 75: Output torque 76: Input current				
Analog output 1 to 9 bias	The bias effect is: (gain*analog value) - bias parameter	0~6553.5	%	0	
Analog output 1~9 gain	The gain effect is: [analog value - (bias parameter - 10V)]	0~6553.5	%	0	

6.2.6 Expand Parameters

6.2.6.1 Encoder Parameters

Name	Content	Predetermined area	unit	Factory settings	Remark
Encoder pulse number	Set the number of encoder pulses	0~65535	ppr	600	

6.2.6.2 Communication Parameters

Name	Content	Predetermined area	unit	Factory settings	Remark
------	---------	--------------------	------	------------------	--------

Name	Content	Predetermined area	unit	Factory settings	Remark
Modbus communication address of this machine	Set the local Modbus communication address	1~99	×	1	
Maximum allowable time for Modbus communication failure	Maximum allowable time for Modbus communication failure	0~60	s	30	The maximum allowed time is 1/4 of this parameter
Modbus function enabled	0: Disable 1: Enable	0~1	×	0	When disabled, this communication fault is not checked
Profibus function enabled	0: Disable 1: Enable	0~1	×	0	When disabled, this communication fault is not checked
Profibus communication address of this machine	Set the local Profibus communication address	1~65535	×	1	
Maximum allowable time for Profibus communication failure	Maximum allowable time for Profibus communication failure	0~60	s	30	

6.2.7 Display Parameters

6.2.7.1 Drive Information Parameters

In the drive information parameters, set the drive version number, rated value, AD offset, etc.

Name	Content	Predetermined area	unit	Factory settings	Remark
Drive rated power	Rated power of the drive	0~6553.5	kW	350	

Drive rated current	Rated current of the drive	0~600	A	10	
Drive rated voltage	Rated voltage of the drive	0~10000	V	6000	

6.2.8 Power unit parameters (Unit Parameters)

6.2.8.1 System bypass parameters (Unit Set Parameters)

In the system bypass parameters, set the number of unit cascades and enable system bypass.

Name	Content	Predetermined area	unit	Factory settings	Remark
System bypass enable	0: Disable 1: Enable	0~1	×	0	
Bypass forced switching time	Rated current of the drive	2000~60000	ms	5000	Time for forced switching to power frequency

6.2.8.2 Unit Passby Parameters

In the unit bypass parameters, set the bypass related parameters.

Name	Content	Predetermined area	unit	Factory settings	Remark
Unit Bypass Enable	0: Disable 1: Enable	0~1	×	0	

7. Debugging steps

7.1 Pre-commissioning instructions

This chapter outlines the steps necessary to successfully start the RVE1000 series medium voltage drive, from visual inspection before power-on to complete medium voltage motor testing. These checks are presented separately according to the different stages of the startup process. Each introductory text and prompt contains a series of separate steps. Some chapters may contain tables to record parameter settings, test point data and any errors or deviations from expected values. The process outlined in this chapter assumes that the drive has been correctly installed.

The RVE1000 series medium voltage drive must be commissioned under the guidance of our company's professionals or with the commissioning documents provided by our company. Functional testing, commissioning and parameter setting must be carried out in strict accordance with relevant regulations and our company's medium voltage drive manual. During commissioning, the user must provide at least two professional electrical technicians as the necessary operating members for commissioning, who must meet the following conditions:

- Familiar with medium voltage electrical equipment and corresponding safety regulations.
- Familiar with the user's load transmission process.
- Authorized to operate medium voltage equipment (power circuit breakers and other medium voltage transmission switches, etc.).
- Authorized to operate transmission equipment.



Notice

WARNING!! Consider the heat dissipation requirements and keep the fan power supply normal when supplying medium voltage to the drive.

Note: Never disconnect the control power supply when the medium voltage part is energized, otherwise the cooling system will stop working, which may cause serious overheating of the system and damage the unit.

Note: Proper drive setup requires measurements with a three-phase voltage regulator, DC voltmeter, AC voltmeter, and dual-trace oscilloscope.



Danger

Electrical hazard! If the drive is not properly installed and inspected, the following test steps may cause serious injury or life-threatening. Before starting, remember to disconnect the drive power supply and comply with the correct interlocking and warning tagging and other related operating procedures.

Electrical hazard! Even after the medium voltage circuit breaker is disconnected and the control power switch is turned off, there may still be dangerous voltages in the RVE1000 drive cabinet (for example, there is stored energy inside the unit).

7.2 Visual inspection before power-on

The drive must be visually inspected before power-on. Check the system specifications detailed below.

Table 7-1 Visual inspection before power-on

Step	Describe
1	Check if the input power meets the drive specifications. Please refer to the drive nameplate for the drive parameters.
2	The drive rated output voltage on the drive nameplate should match the motor rated voltage on the motor nameplate.
3	The control voltage (low voltage) must be a four-wire three-phase 380V power supply.
4	The rated power on the motor nameplate must match the rated power of the drive.
5	Confirm that the two medium voltage input cables that short the neutral point of the transformer are tightly connected to the three taps of the transformer. These connectors should be the +0% taps of the three sets of transformer coils.
6	Make sure all cabinets are properly connected and the grounding between cabinets is connected.
7	Check all connections and wiring to ensure they are connected correctly and securely. Confirm that all electrical connection points (including the main circuit) are marked with tightening marks and are not loose.
8	Verify that there is no cabinet damage or severe exterior paint loss. If there is, check the integrity of components, cables or other materials behind or below the damaged area.
9	Check the cables at all separation points or gaps to ensure that there are no cable chafing.
10	Check all terminal blocks, fixings, units and other parts for markings or labels. If there is any discrepancy with the drawings or instructions, inform the factory.
11	Verify that the fan cover is installed and that the fan rotates freely.
12	Make sure control and main power connections are correct and in accordance with local electrical codes.
13	Check all user connections for tightness and correctness.
14	Standard safety precautions and local regulations must be followed when installing external wiring. The routing distance between medium voltage cables and low-voltage cables must be maintained.
15	To maintain electromagnetic compatibility, shielded cables must be used for wiring weak signals such as analog signals and encoder signals.

Note: If any of the above inspections are inconsistent or abnormal, please notify the manufacturer.

7.3 Insulation resistance inspection

The insulation resistance inspection must be arranged as the last step before power-on to ensure that there is no obvious time interval between the insulation test and the power-on. The insulation resistance of the corresponding circuit should be measured, and the result should meet the requirements of Table 7-2.

Table 7-2 Insulation test requirements

Circuit nominal voltage	Meter level	Insulation resistance (MΩ)
Below 120VAC	250VDC	≥0.25
Below 500VAC	500VDC	≥0.5
Below 1000VAC	1000VDC	≥1.0
3000VAC and above	2500VDC	≥3.0

The higher the actual insulation value of the test, the better. For example, the low voltage reaches 500 MΩ and the medium voltage reaches 2500 MΩ. If the insulation value is relatively small, you should consider whether it is related to air humidity or rain! At this time, you can use a heater to heat the cabinet for a period of time, and retest the insulation after the heating is over.

During the insulation test, some relative insulation may be zero, which is due to the existence of some working grounding wires. For example, the secondary grounding of the control transformer. At this time, you can remove these grounding wires and do the test again. After the test is qualified, restore these connections.



When checking the insulation of the input and output medium voltage cables, the user must disconnect the power cabinet cables, motor cables and the drive. Do not test the insulation with the drive. Especially when the drive is connected to the output side, insulation testing may damage the internal components of the drive and is absolutely not allowed.

7.4 Power unit and communication test

This test can be completed by a three-phase voltage regulator (0-380V adjustable, capacity not less than 10KVA) and a touch screen. Voltage can be provided to all units.

Table 7-3 Power unit and communication test

Step	Describe
1	Disconnect the drive from the electrical connection with the front-end power supply, and disconnect the drive from the load motor.
2	<p>Connect the output of the three-phase voltage regulator to the input of unit B1 and close the door of the transformer cabinet.</p> <div data-bbox="196 566 381 635" style="border: 1px solid black; padding: 5px; display: inline-block;">  Danger </div> <p>ELECTRICAL HAZARD: The transformer cabinet door must be closed before starting this procedure because medium voltage will be induced on the medium voltage input side.</p>
3	<p>Turn on the control power of the control cabinet and check whether the control part can be initialized normally. The power-on sequence of the control power is: first turn on all the power distribution switches on the top of the transformer cabinet, close the cabinet door, and close the outer door coupling switch. Then turn on the UPS (press ON for 5 seconds). The startup time of the UPS is about 10 seconds. After the UPS outputs normally, turn on all the remaining single switches. Check that the green indicator lights of all switch power boxes are on, the touch screen is lit, and there is no abnormality in the display.</p>
4	<p>Turn on the three-phase voltage regulator and slowly increase the output voltage to about 75V.</p> <ul style="list-style-type: none"> • Measure the input voltage of all units to confirm that they can all accept almost the same voltage. • If all voltages are normal, continue to increase the voltage of the three-phase voltage regulator to 200VAC and check whether the circuit boards of all power units are lit (two lights on the circuit board). At the same time, the real-time values of the unit temperature and bus voltage can be seen on the monitoring screen. At this time, the unit bus voltage is about $200 \times 1.414 = 283V$.
5	Through the touch screen, SOP settings, shielding unit fiber upload fault, PWM start fault, input undervoltage fault.
6	<p>Give the drive any frequency and start the drive</p> <ul style="list-style-type: none"> • Confirm that the 4 parallel LED indicators (Q1 – Q4) on each unit control board are not lit.
7	<p>Stop the drive operation</p> <p>Shut off the control power supply and the three-phase voltage regulator power supply, and remove the connection between the three-phase voltage regulator and the B1 unit.</p>
8	<p>Through SOP settings, the unit fiber upload failure, PWM start failure, and input undervoltage failure can be restored. Otherwise, the system cannot protect against such failures, leaving safety risks.</p>

7.5 Drive test without motor

The following steps are to test the operation of the drive (without motor).

Table 7-4 Drive test without motor

Step	Describe
1	Lock the doors of the unit cabinet and transformer cabinet.
2	Reapply AC control power.
3	According to the order of the drawings, put the circuit breaker inside the control cabinet, turn on the UPS power (press and hold ON for 5 seconds). Confirm that the power supply of each control part is normal and the touch screen display is normal.
4	<p>Turn on the medium voltage power supply.</p> <div style="border: 1px solid black; padding: 5px; display: inline-block;">  Notice </div> <p>The power-on sequence of AC control power supply and medium voltage power supply cannot be reversed. The control power supply must be supplied first, and then the medium voltage power supply can be supplied after the control system works normally. The power-off sequence is the opposite!</p>
5	The input power supply voltage values displayed on the main monitoring screen are normal and can be compared with the power supply voltage detection values at the user end to confirm whether the power supply is normal; confirm that the unit voltage display is normal.
6	Set the "control mode parameter" to 0 (i.e. VF control), set the "VF modulation ratio parameter" to 1.0, and then input a 50Hz speed command to start the drive.

7.6 Drive with motor test

The following steps verify the operation of the drive (with the motor connected to the output). During this test, the motor should not be loaded. Wait until the motor can start and stop normally before starting the load test.

Table 7-5 Drive with motor test

Step	Describe
1	Disconnect the medium voltage power supply and control power supply, and electrically connect the motor and drive together.
2	Reapply control power.

Step	Describe																																													
3	<p>(1) Set the motor parameters to be consistent with the motor nameplate values;</p> <p>(2) Set the drive parameters to be consistent with the drive configuration;</p> <p>(3) Set the "command channel selection parameters" according to the command setting method;</p> <p>(4) If analog input is used, set the "frequency channel selection parameters" according to the frequency setting method, and set the analog offset and gain parameters according to the external analog setting range.</p>																																													
4	<p>(1) Confirm the common parameters as follows:</p> <table border="1" data-bbox="196 478 952 678"> <thead> <tr> <th>Name</th> <th>Unit</th> <th>Factory settings</th> </tr> </thead> <tbody> <tr> <td>Control mode</td> <td>×</td> <td>0</td> </tr> <tr> <td>Command channel selection</td> <td>×</td> <td>0</td> </tr> <tr> <td>Frequency channel selection</td> <td>×</td> <td>0</td> </tr> <tr> <td>Direction channel selection</td> <td>×</td> <td>0</td> </tr> </tbody> </table> <p>(2) Confirm that the S-curve parameters are as follows:</p> <table border="1" data-bbox="196 742 952 869"> <thead> <tr> <th>Name</th> <th>Unit</th> <th>Factory settings</th> </tr> </thead> <tbody> <tr> <td>Acceleration time T0</td> <td>s</td> <td>60</td> </tr> <tr> <td>Deceleration time T0</td> <td>s</td> <td>90</td> </tr> </tbody> </table> <p>(3) Confirm that the start parameter P13 is as follows:</p> <table border="1" data-bbox="196 933 952 1013"> <thead> <tr> <th>Name</th> <th>Unit</th> <th>Factory settings</th> </tr> </thead> <tbody> <tr> <td>Startup mode selection</td> <td>×</td> <td>0</td> </tr> </tbody> </table> <p>(4) Confirm that the stop parameter P14 is as follows:</p> <table border="1" data-bbox="196 1077 952 1157"> <thead> <tr> <th>Name</th> <th>Unit</th> <th>Factory settings</th> </tr> </thead> <tbody> <tr> <td>Parking mode selection</td> <td>×</td> <td>0</td> </tr> </tbody> </table> <p>(5) Confirm that the general parameters are consistent with the motor nameplate.</p> <p>(6) Confirm that the frequency limit parameters are as follows:</p> <table border="1" data-bbox="196 1284 952 1412"> <thead> <tr> <th>Name</th> <th>Unit</th> <th>Factory settings</th> </tr> </thead> <tbody> <tr> <td>Maximum frequency</td> <td>Hz</td> <td>50</td> </tr> <tr> <td>Minimum frequency</td> <td>Hz</td> <td>0</td> </tr> </tbody> </table>	Name	Unit	Factory settings	Control mode	×	0	Command channel selection	×	0	Frequency channel selection	×	0	Direction channel selection	×	0	Name	Unit	Factory settings	Acceleration time T0	s	60	Deceleration time T0	s	90	Name	Unit	Factory settings	Startup mode selection	×	0	Name	Unit	Factory settings	Parking mode selection	×	0	Name	Unit	Factory settings	Maximum frequency	Hz	50	Minimum frequency	Hz	0
Name	Unit	Factory settings																																												
Control mode	×	0																																												
Command channel selection	×	0																																												
Frequency channel selection	×	0																																												
Direction channel selection	×	0																																												
Name	Unit	Factory settings																																												
Acceleration time T0	s	60																																												
Deceleration time T0	s	90																																												
Name	Unit	Factory settings																																												
Startup mode selection	×	0																																												
Name	Unit	Factory settings																																												
Parking mode selection	×	0																																												
Name	Unit	Factory settings																																												
Maximum frequency	Hz	50																																												
Minimum frequency	Hz	0																																												

Step	Describe																																																																											
	<p>(7) Confirm that the digital input parameters are as follows:</p> <table border="1" data-bbox="196 231 952 805"> <thead> <tr> <th>Name</th> <th>Unit</th> <th>Factory settings</th> </tr> </thead> <tbody> <tr><td>Digital input 1 function definition</td><td>×</td><td>3</td></tr> <tr><td>Digital input 2 function definition</td><td>×</td><td>8</td></tr> <tr><td>Digital input 3 function definition</td><td>×</td><td>9</td></tr> <tr><td>Digital input 4 function definition</td><td>×</td><td>10</td></tr> <tr><td>Digital input 5 function definition</td><td>×</td><td>8</td></tr> <tr><td>Digital input 6 function definition</td><td>×</td><td>7</td></tr> <tr><td>Digital input 7 function definition</td><td>×</td><td>6</td></tr> <tr><td>Digital input 8 function definition</td><td>×</td><td>11</td></tr> <tr><td>Digital input 9 function definition</td><td>×</td><td>4</td></tr> <tr><td>Digital input 10 function definition</td><td>×</td><td>0</td></tr> <tr><td>Digital input 11 function definition</td><td>×</td><td>0</td></tr> <tr><td>Digital input 12 function definition</td><td>×</td><td>17</td></tr> <tr><td>Digital input 13 function definition</td><td>×</td><td>19</td></tr> <tr><td>Digital input 14 function definition</td><td>×</td><td>18</td></tr> <tr><td>Digital input 15 function definition</td><td>×</td><td>0</td></tr> </tbody> </table> <p>(8) Confirm that the digital output parameters are as follows:</p> <table border="1" data-bbox="196 869 952 1125"> <thead> <tr> <th>Name</th> <th>Unit</th> <th>Factory settings</th> </tr> </thead> <tbody> <tr><td>Digital output 0 function definition</td><td>×</td><td>5</td></tr> <tr><td>Digital output 1 function definition</td><td>×</td><td>9</td></tr> <tr><td>Digital output 2 function definition</td><td>×</td><td>6</td></tr> <tr><td>Digital output 3 function definition</td><td>×</td><td>3</td></tr> <tr><td>Digital output 4 function definition</td><td>×</td><td>1</td></tr> <tr><td>Digital output 5 function definition</td><td>×</td><td>2</td></tr> </tbody> </table> <p>(9) Confirm that the unit bypass parameters are as follows:</p> <table border="1" data-bbox="196 1181 952 1252"> <thead> <tr> <th>Name</th> <th>Unit</th> <th>Factory settings</th> </tr> </thead> <tbody> <tr> <td>Unit Bypass Enable</td> <td>×</td> <td>0</td> </tr> </tbody> </table>	Name	Unit	Factory settings	Digital input 1 function definition	×	3	Digital input 2 function definition	×	8	Digital input 3 function definition	×	9	Digital input 4 function definition	×	10	Digital input 5 function definition	×	8	Digital input 6 function definition	×	7	Digital input 7 function definition	×	6	Digital input 8 function definition	×	11	Digital input 9 function definition	×	4	Digital input 10 function definition	×	0	Digital input 11 function definition	×	0	Digital input 12 function definition	×	17	Digital input 13 function definition	×	19	Digital input 14 function definition	×	18	Digital input 15 function definition	×	0	Name	Unit	Factory settings	Digital output 0 function definition	×	5	Digital output 1 function definition	×	9	Digital output 2 function definition	×	6	Digital output 3 function definition	×	3	Digital output 4 function definition	×	1	Digital output 5 function definition	×	2	Name	Unit	Factory settings	Unit Bypass Enable	×	0
Name	Unit	Factory settings																																																																										
Digital input 1 function definition	×	3																																																																										
Digital input 2 function definition	×	8																																																																										
Digital input 3 function definition	×	9																																																																										
Digital input 4 function definition	×	10																																																																										
Digital input 5 function definition	×	8																																																																										
Digital input 6 function definition	×	7																																																																										
Digital input 7 function definition	×	6																																																																										
Digital input 8 function definition	×	11																																																																										
Digital input 9 function definition	×	4																																																																										
Digital input 10 function definition	×	0																																																																										
Digital input 11 function definition	×	0																																																																										
Digital input 12 function definition	×	17																																																																										
Digital input 13 function definition	×	19																																																																										
Digital input 14 function definition	×	18																																																																										
Digital input 15 function definition	×	0																																																																										
Name	Unit	Factory settings																																																																										
Digital output 0 function definition	×	5																																																																										
Digital output 1 function definition	×	9																																																																										
Digital output 2 function definition	×	6																																																																										
Digital output 3 function definition	×	3																																																																										
Digital output 4 function definition	×	1																																																																										
Digital output 5 function definition	×	2																																																																										
Name	Unit	Factory settings																																																																										
Unit Bypass Enable	×	0																																																																										
5	<p>Make the motor rotate at 10Hz and observe whether the rotation direction is correct. If it is not correct, change the default rotation direction by modifying the "Motor Phase Sequence Parameter" in the "Motor Basic Parameter Type".</p>																																																																											
6	<p>Set a 30Hz speed segment to start the drive normally. After the motor is driven, it starts to rotate and accelerate. After accelerating to the given speed, observe whether the motor runs smoothly and whether there is any abnormal noise. If there is no abnormality, you can stop the machine for load testing.</p>																																																																											

7.7 Important parameter setting instructions

7.7.1 Analog calibration

Input analog debugging

Take the 0~20mA port connected to a 4~20mA external signal as an example, the debugging steps are as follows:

Step1. First set the "Analog input type" parameter to 4, the "Analog input function definition" parameter to 1, the "Analog input bias" parameter to 10, and the "Analog input gain" parameter to 100%;

Step2. Given a 4mA analog quantity, if the interface given frequency is not 0, reduce the "Analog input bias" parameter; if the interface given frequency is 0, increase the "Analog input bias" parameter, and make sure that the interface given frequency just displays 0 (slightly increase it, the target frequency is not zero)

Step3. Given a 20mA analog quantity, if the interface given frequency is $\geq 50.00\text{Hz}$, reduce the "Analog input gain" parameter; if the interface given frequency is $< 50.00\text{Hz}$, increase the "Analog input gain" parameter;

Step4. Given a 10mA analog quantity (output gain set to 37.5%), verify that the parameter settings are correct (corresponding to a target frequency of about 25Hz).

Output analog quantity debugging

- IO board analog quantity output active power

Set analog quantity output channel 1 function to 62, offset to 50%, gain to 50% (this channel is $\pm 10\text{V}$, only 0~10V output is required), and fine-tuning is required.

- Output U_r , U_s , U_t

Set the output channel function to 64\65\66, offset to 50%, gain to 100%.

7.7.2 Frequency hopping function description

When the set frequency is within the jump frequency range, the actual operating frequency will be the jump frequency boundary.

By setting the jump frequency, the drive speed regulation system can avoid the mechanical resonance point of the load. This variable frequency speed regulation system can set 3 jump frequency points.

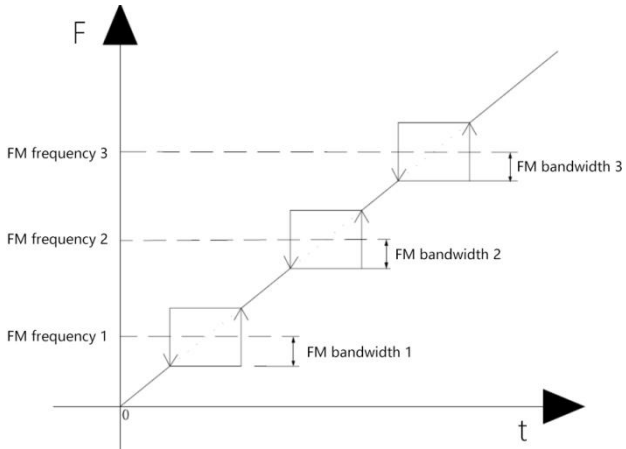

Figure 7-1 Frequency hopping function diagram

8. Alarm information and troubleshooting

RVE1000 series medium voltage drive have perfect alarm and fault protection functions, among which faults are divided into four categories: unit fault, system fault, bypass fault and other faults.

Fault function: The system can clearly indicate the fault situation, and automatically perform actions such as power unit bypass, protection shutdown, and even cut off medium voltage input according to the fault level. According to different alarm or fault levels, the human-machine interface fault indicator will display different colors, and the fault situation can be quickly judged based on the displayed fault information.

Alarm function: When an abnormality that is not destructive occurs, the system will alarm. The system will not shut down during the alarm process, but the human-machine interface fault indicator will turn yellow, and the alarm situation can be quickly judged based on the displayed alarm information.

8.1 Fault code and fault name

Please refer to Appendix 1. This appendix summarizes the fault names for the convenience of drive users to consult and use.

8.2 Faults and countermeasures

When an alarm/fault occurs, please refer to Tables 8-1 to 8-4 to troubleshoot the fault.

8.2.1 System faults and countermeasures

Table 8-1 System faults and countermeasures

Fault name	Type	Possible Causes	Countermeasures
Speeding	Alarm/Fault	Speed feedback exceeds the overspeed setting value	1. Make sure the encoder is set correctly 2. If the overshoot is too large, the inertia needs to be adjusted 3. Adjust the "overspeed protection parameters"

Fault name	Type	Possible Causes	Countermeasures
overload	none	The grid voltage is too low	Check the grid voltage
		The motor rated current is incorrectly set	Reset the motor rated current
		The motor is stalled or the load is too sudden	Check the load and adjust the torque boost
		The drive and motor power do not match	Select a matching motor
Input side overcurrent	none	Effective value of the drive input current exceeds the protection limit	1. Check the "motor rated current parameter" 2. Check the "drive input current sensor current maximum value parameter"
		Acceleration is too fast	Increase the "acceleration time T0 parameter"
Input side phase loss	Alarm/Fault	Input side wiring connection error	Check the input wiring
		Medium voltage sampling resistor damaged	Check whether the sampling resistor is normal, 2.1MΩ for 3kV, 4.2MΩ for 6kV, and 7MΩ for 10kV
		Input power supply phase missing	Check whether the medium voltage power supply is missing a phase
Input phase imbalance	Alarm/Fault	The drive input side wiring is abnormal, missing or broken	Check the three-phase voltage on the input side
		The input power phase is unbalanced	Check the three-phase power supply
		The input voltage sampling circuit of the acquisition board is damaged	Replace the signal acquisition board or sampling resistor

Fault name	Type	Possible Causes	Countermeasures
Input side undervoltage	Alarm/Fault	The grid voltage is too low (<70% rated)	Check the grid input power supply
		Parameter setting is improper	Check the "motor rated voltage parameter", "drive input voltage sensor voltage maximum parameter"
		The input voltage sampling circuit of the acquisition board is damaged	Replace the acquisition board
Input side overvoltage	Alarm/Fault	Acquisition board input voltage sampling circuit is damaged	Check the grid input power supply
		Grid voltage is too medium (>110% rated); the input side voltage is higher than the overvoltage protection limit	Check the input side overvoltage protection parameters and sensor parameter settings
		Acquisition board input voltage sampling circuit is damaged	Replace the acquisition board
Output side overcurrent	Alarm/Fault	Acceleration too fast	Increase acceleration time
		Load inertia torque is large	Set VF low frequency compensation to 110%
		Parameter setting is improper	Check "motor rated current parameters", "drive rated current parameters", "drive rated current sensor current maximum parameters"
		Output current detection line problem	Check whether the output current circuit wiring is correct and firm.
Output side phase loss	none	The drive output three-phase is seriously asymmetric	<ol style="list-style-type: none"> 1. Check the output wiring 2. The output terminal is loose 3. Check the motor and cable

Fault name	Type	Possible Causes	Countermeasures
Output ground fault	none	Single-phase grounding of the external output cable or motor	1. Check whether the external cables and motor are grounded 2. Disconnect the drive from the motor and use a megohmmeter to check the insulation of the motor and motor cable
Output open circuit	none	Drive output line disconnection	Check if all connections to the motor are tight
Output instantaneous overcurrent	Fault	Acceleration too fast	Increase acceleration time
		Load inertia torque is large	Set VF low frequency compensation to 110%
		Parameter setting is improper	Check "motor rated current parameter", "drive rated current", "drive rated current sensor current maximum parameter"
		Load is too light at startup	Set VF low frequency compensation to 110%
Output phase imbalance	none	Drive output side wiring is abnormal, missing or disconnected	Check the drive output wiring to eliminate missing connections and broken wires
		Input voltage sampling circuit of the acquisition board is damaged	Replace the signal acquisition board or sampling resistor
Output side overvoltage	none	The setting values in the motor parameters and drive parameters are inconsistent with the rated values of the drive and motor	Check if the motor parameters and drive parameters are set appropriately
CAN communication failure	Alarm/Fault	Communication interface is loose	Check the communication interface
		Communication line connection is not standard	Use twisted pair and connect CANH, CANL, GND

Fault name	Type	Possible Causes	Countermeasures
Communication failure	none	Baud rate setting is improper	Set the appropriate baud rate
		Communication interface is loose	Check the communication interface
		Communication line is damaged	Replace the communication line
Fiber optic communication failure	none	Fiber head loose	Reconnect
		Fiber damaged	Replace the optical fiber
HMI communication failure	none	Improper baud rate setting	Set the appropriate baud rate
		Communication interface loose	Reconnect the communication port
		Communication connection line damaged	Replace the communication line
Bypass board uplink communication failure	Alarm	Fiber head loose	Reconnect the optical fiber head
		Fiber damaged	Replace the optical fiber
		Bypass board not working	Seek technical service
Bypass board downstream communication failure	none	Fiber head loose	Reconnect the optical fiber head
		Fiber damaged	Replace the optical fiber
Cabinet door open	Alarm	Cabinet door not closed	Check if the cabinet door is closed
		Door travel switch damaged	Replace the travel switch
		Electrical circuit disconnected	Check if there is a fault in the circuit according to the electrical drawing

Fault name	Type	Possible Causes	Countermeasures
Transformer overheating	Alarm/Fault	Ambient temperature too high	<ol style="list-style-type: none"> 1. Turn on the air conditioner or increase the space cooling power 2. Check whether the drive installation environment meets the requirements
		Transformer temperature measuring resistance circuit wiring problem	<ol style="list-style-type: none"> 1. Check whether the shield of the control temperature measuring resistor cable is properly grounded. 2. Check whether the temperature measuring circuit is broken according to the drawing.
Transformer fan thermal relay tripped	Alarm	The fan is overheated or stalled, causing the fan thermal relay to trip	<ol style="list-style-type: none"> 1. Check if the fan is blocked or reversed 2. Check if the thermal relay is normal 3. Check if the filter is blocked
		The transformer's built-in fan stops	<ol style="list-style-type: none"> 1. Check if the bottom fan is damaged 2. Check if there is any abnormality in the fan circuit according to the drawing.
		Transformer fan thermal relay tripped Signal line not properly connected to IO board	Check the fan circuit connection according to the electrical drawing to see if there is any abnormality
Unit fan thermal relay tripped	Alarm	The fan is overheated or blocked, causing the fan thermal relay to trip.	<ol style="list-style-type: none"> 1. Check if the fan is blocked or reversed 2. Check if the thermal relay is normal 3. Check if the filter is blocked
		Transformer fan thermal relay tripped Signal line not properly connected to IO board	Check the fan circuit connection according to the electrical drawing to see if there is any abnormality

Fault name	Type	Possible Causes	Countermeasures
UPS failure, i.e. medium voltage power outage	Alarm	UPS electrical circuit failure	Check the UPS circuit connection according to the electrical drawing to see if there is any abnormality
		UPS is damaged	Replace UPS
The fan is not powered on	Alarm	The fan has no power input	Turn on the power supply of the fan
		The fan electrical circuit is abnormal	Check the fan circuit connection for abnormalities according to the electrical drawings
User external fault	Fault	The outdoor fault signal line is not correctly connected to the IO board	Check the electrical circuit for abnormalities and correct operation according to the electrical drawings
Overheating	Alarm/Fault	The ambient temperature is too high	Turn on the refrigeration equipment to cool the space or increase the space cooling power
		The space cooling circuit is faulty	Check the space cooling circuit
		The electrical detection circuit is abnormal	Check the circuit for abnormalities according to the electrical drawings
Excessive humidity	Alarm/Fault	The ambient humidity is too high	Dehumidify the environment with air conditioning or other equipment
		The detection circuit is faulty	Check the circuit for abnormalities according to the electrical drawings
		The control cable shield is not properly grounded	Check whether the shielding of the control cable is properly grounded
RTC Failure	Alarm	RTC does not work properly	Check if the battery is charged

Fault name	Type	Possible Causes	Countermeasures
Modbus communication failure	Alarm/Fault	Communication interface is loose	Check the communication interface
		ID address setting error	Set the communication address parameters
Analog disconnection fault	Alarm	Analog given line is off	Connect the analog given line
		AD input channel is damaged	Change an analog input channel
Profibus communication failure	Fault	Communication interface is loose	Check the communication interface
		ID address setting is wrong	Set the Anybus card address
Vacuum contactor K1~K6 fault	Fault	The feedback status of the vacuum contactor is inconsistent with the given	<ol style="list-style-type: none"> 1. Check whether the IO board command is given 2. Check the electrical connection of the vacuum contactor
External 380VAC power failure	Alarm	External 380VAC power failure	Confirm that the external 380VAC power is off
		380VAC power failure signal line is disconnected	Check the signal line
The phase sequence of power frequency conversion is inconsistent (only when >10Hz)	Alarm/Fault	The power frequency phase sequence is inconsistent with the variable frequency phase sequence	Confirm that the power frequency phase sequence is inconsistent with the variable frequency phase sequence. Check if there is any crossover in the input and output sampling lines.
		The input and output sampling lines are crossed (output A, B, C do not correspond to the sampling triangle resistance)	Confirm that the power frequency phase sequence is inconsistent with the variable frequency phase sequence. Check if there is any crossover in the input and output sampling lines.

Fault name	Type	Possible Causes	Countermeasures
Vacuum contactors act simultaneously	Fault	Vacuum contactor feedback contact error	Check feedback contacts
IO expansion board CAN communication failure	Alarm/Fault	The communication interface is loose	Check the communication interface
		The communication line connection is not standard	Use twisted pair and connect CANH, CANL, GND
Acquisition board CAN communication failure	Alarm/Fault	The communication interface is loose	Check the communication interface
		The communication line connection is not standard	Use twisted pair and connect CANH, CANL, GND

Actions after system failure

1. After a system failure occurs, the system will save the fault information and display it on the human-machine interface. At the same time, the fault indicator light will be yellow when the alarm is on and red when the fault occurs.
2. The system will not stop when the alarm is on.
3. When a fault occurs, the system will immediately block PWM and stop freely. For serious system failures, such as when the temperature of the phase-shifting transformer exceeds the fault threshold, the system will cut off the medium voltage input on the basis of stopping.

8.2.2 Unit failure and countermeasures

Table 8-2 Unit failure and countermeasures

Fault name	Type	Possible Causes	Countermeasures
Unit short circuit fault	Fault	Unit output short circuit	Check if the unit is damaged, replace it if damaged
		Unit drive failure	Replace the driver board
		Output motor line short circuit	Check the output cable

Fault name	Type	Possible Causes	Countermeasures
Unit overvoltage fault	Alarm/Fault	Deceleration too fast	Set a longer deceleration time
		Grid voltage too high	Reduce the input voltage
Unit overheat fault	Alarm/Fault	Filter blockage	Clean the dust filter
		Cooling fan stopped	Check if the fan is normal
		Cooling fan reversed	Check if the fan direction is the same
		Cooling channel blocked	Check if the external channel is blocked
		Cabinet sealing is not good	Check if the cabinet door is closed
		Ambient temperature is too high	Install a larger refrigeration device
Unit equalization fault	Alarm/Fault	Equalizing resistor wiring is loose	Check the voltage-equalizing resistor connection of the unit
		Equalizing resistor damaged	Check if the DC bus capacitor is intact, replace the capacitor
		DC bus capacitor damaged	Check if the DC bus capacitor is intact
Uplink fiber failure (unit sends to master)	Alarm/Fault	Fiber connector loose	Check whether it is illuminated, and compare it with other unit optical fibers. If the light is abnormal, please replace the optical fiber
		Unit fault	Replace the driver board or unit
		Unit not powered on (medium voltage alarm disappears)	Check whether the output undervoltage fault is shielded
Downstream fiber failure (sent from master to unit)	Alarm/Fault	Fiber connector loose	Check whether it is illuminated, and compare it with other main board optical fibers. If the light is abnormal, please replace the optical fiber
		Fiber not emitting light	Replace the main control board

Fault name	Type	Possible Causes	Countermeasures
PWM lockout (i.e. lockout during operation) fault	Fault	Unit FPGA crystal not vibrating	Replace the driver board
		Unit not receiving main control fiber PWM	Reference optical fiber communication fault
PWM ON FAULT	Alarm/Fault	Fiber communication not smooth	Reference optical fiber communication fault
		Unit not powered on	Detect SOP shielding input undervoltage fault
Unit phase loss	Alarm/Fault	Unit incoming line missing phase	Check whether the unit incoming line and the secondary side of the transformer are off
		High voltage missing phase	Check whether the drive power supply is missing phase, refer to input missing phase
		Phase-shifting rectifier transformer damaged	Seek technical service

Actions after unit failure

1. When the unit alarms, the system continues to run and saves the alarm information, and the fault indicator light is yellow.
2. If the unit bypass is not enabled, when the unit fails, the system blocks PWM, reports the fault information, and stops the system.
3. If the unit bypass is enabled, the unit reports the fault information, the system bypasses the unit and runs at a reduced rating.

8.2.3 Bypass failure and its countermeasures

Table 8-3 Bypass failure and its countermeasures

Fault name	Type	Possible Causes	Countermeasures
A~C phase bypass fault	Fault	The number of unit bypasses exceeds the set maximum value	Determine if the number of unit bypasses exceeds the set maximum value
		Bypass board feedback is inconsistent with bypass command	Check bypass board communication

Action after bypass fault

When the system bypass is enabled, if bypass fault information is reported, PWM is blocked and the system stops.

8.2.4 Other faults and their countermeasures

Table 8-4 Other faults and their countermeasures

Fault name	Type	Possible Causes	Countermeasures
Watchdog reset fault	Fault	Program is out of order	Replace the motherboard
		Motherboard ARM crystal is not vibrating	Replace the motherboard

Other actions after faults

When a watchdog reset fault occurs, the fault information is saved, PWM is blocked, and the system stops freely.

9. Communication protocol

9.1 MODBUS function and address

9.1.1 Description

*Note: When writing to an "unused" bit or register, please write 0;

Do not write any data to a "reserved" bit or register.

(1) If the unit is WORD and the starting address starts from 0, the register address is calculated as follows:

Register Modbus address = register address

Register bit Modbus address = register address * 16 + bit number n (n = 0, ..., 15)

(2) If the unit is BYTE and the starting address starts from 0, the register address is calculated as follows:

Register Modbus address = register address * 2, register address * 2 + 1 (high 8 bits, low 8 bits depending on the situation)

Register bit Modbus address = register address * 16 + bit number n (n = 0, ..., 15)

(3) If the unit is WORD and the starting address starts from 1, the register address is calculated as follows:

Register Modbus address = register address + 1

Register bit Modbus address = register address * 16 + bit number n + 1 (n = 0, ..., 15)

(4) If the unit is BYTE and the starting address starts from 1, the register address calculation method is as follows:

Register Modbus address = register address * 2 + 1, register address * 2 + 2 (high 8 bits, low 8 bits depending on the situation)

Register bit Modbus address = register address * 16 + bit number n + 1 (n = 0, ..., 15)

9.1.2 Modbus protocol

9.1.2.1 Communication protocol description

(1) Communication function code description

Function code "3": Read line holding register (i.e. read command word register)

Function code "6": Write line holding register (i.e. write command word register)

Function code "1": Read coil status (i.e. read command bit register)

Function code "5": Write coil status (i.e. write command bit register)

Function code "2": Read input status (i.e. read status bit register)

Function code "4": Read input register (i.e. read status word register)

9.1.2.2 Communication protocol

Host (DCS) sends

Slave Address	Function Code	High start address	Low start address	Number of high registers	Number of low registers	CRC check high 8 bits	CRC check lower 8 bits
1Byte	1Byte	1Byte	1Byte	1Byte	1Byte	1Byte	1Byte

Return from the machine

Slave Address	Function Code	Data length (byte)	Number of high registers	Number of low registers	...	CRC check high 8 bits	CRC check lower 8 bits
1Byte	1Byte	1Byte	1Byte	1Byte	2n Byte	1Byte	1Byte

9.1.2.3 Instruction data [Register 3, 6] [Bit 1, 5]

Register Address	Content
0000H	Operational control bit0 1: Forward 0: invalid bit1 1: Reversal 0: invalid bit2 1: Run 0: Stop bit3 1: Emergency Stop 0: invalid bit4 1: Power frequency conversion 0: invalid bit5 1: Variable frequency to industrial frequency 0: invalid bit6 1: Water Pump Emergency Stop bit7 1: Power frequency Start 0: Power frequency Stop bit8 1: Soft Start 0: invalid bit15~9 unused*
0001H	Modbus target frequency setting value 0~10000: 0.00~100.00Hz
0002H	Reserve
0003H	Modbus speed setting 0~15
0004H	Reset Command bit0 Reserve bit1 1: Self-test reset 0: invalid bit2 1: Fault reset 0: Stop bit3 Reserve bit4 Reserve bit5 Reserve Bit6 1: Power unit reset 0: invalid Bit7 1: Bypass board reset 0: invalid bit1 5~8 Not used

Register Address	Content
0005H	Multi-function port output # (IO port provided for user control)bit0 1: DO0 ON 0: OFF bit1 1: DO1 ON 0: OFF bit2 1: DO2 ON 0: OFF bit3 1: DO3 ON 0: OFF bit4 1: DO4ON 0: OFF bit5 1: DO5ON 0: OFF bit6 1: DO6ON 0: OFF bit7 1: DO7ON 0: OFF bit15~8 unused *Actual terminal output value = Modbus setting value internal output value of function terminal
0006H~0205H	Reserve
0206H	User multi-function input port [refers to the input I/O of the user (Modbus master), so that this system (Modbus slave) can use the master I/O as its own I/O] bit0 1: Multi-function terminal DI0 ON 0: OFF bit1 1: Multi-function terminal DI1 ON 0: OFF bit2 1: Multi-function terminal DI2 ON 0: OFF bit3 1: Multi-function terminal DI3 ON 0: OFF bit4 1: Multi-function terminal DI4 ON 0: OFF bit5 1: Multi-function terminal DI5 ON 0: OFF bit6 1: Multi-function terminal DI6 ON 0: OFF bit7 1: Multi-function terminal DI7 ON 0: OFF bit8 1: Multi-function terminal DI7 ON 0: OFF bit9 1: Multi-function terminal DI7 ON 0: OFF bit10 1: Multi-function terminal DI7 ON 0: OFF bit11 1: Multi-function terminal DI7 ON 0: OFF bit12 1: Multi-function terminal DI7 ON 0: OFF bit13 1: Multi-function terminal DI7 ON 0: OFF bit14 1: Multi-function terminal DI7 ON 0: OFF bit15 1: Multi-function terminal DI7 ON 0: OFF
0207H	Enable water pump command bit0 1: Enable the first water pump ON 0: OFF bit1 1: Enable the second water pump ON 0: OFF bit2 1: Enable the third water pump ON 0: OFF bit3 1: Enable the fourth water pump ON 0: OFF bit4~bit15 Reserved
0208H	Target torque (0.1%, reference value motor rated torque), signed number

9.1.2.4 Monitoring data [Register 4] [Bit 2]

Can only be read.

Register Address	Content
0000H	Drive status bit0 1: self-test bit1 1: alarm bit2 1: Fault bit3 1: Unit bypass bit4 1: System bypass bit5 1: Remote control 0: Local control bit6 1: System closed loop control, 0: System open loop control bit7 1 EEPROM initialization bit8 1: forward 0: reverse bit9 1: soft start bit10 1: Positive (grid phase sequence) 0: Negative (grid phase sequence) bit11 1: Positive (motor phase sequence) 0: Negative (motor phase sequence) bit15~12 unused
0001H	Operating status 0: Idle 1: Forward start 2: Forward 3: Forward stop 4: Reverse start 5: Reversal 6: Reverse stop 7: Forward -> Reverse 8: Reverse -> Forward bit15~9 unused
0002H	Current feedback speed (unit: 0.1rpm, encoder required)
0003H	Current feedback frequency (unit: 0.01Hz, encoder required)
0004H	Output voltage effective value (unit V)
0005H	Output current effective value (unit: 0.1A)
0006H	Input voltage effective value (unit V)

Register Address	Content
0007H	Input current effective value (unit: 0.1A)
0008H	Output active power (unit: 0.1KW)
0009H	Output reactive power (unit: 0.1KW)
000AH	Total output power (unit: 0.1KW)
000BH	Input power (unit: 0.1KW)
000CH	Power Factor
000DH~004CH	Reserve
004DH~004EH	System input terminal status (32 ports) bit0 1: Multi-function terminal DI0 ON 0: OFF bit1 1: Multi-function terminal DI1 ON 0: OFF bit2 1: Multi-function terminal DI2 ON 0: OFF bit3 1: Multi-function terminal DI3 ON 0: OFF bit4 1: Multi-function terminal DI4 ON 0: OFF bit5 1: Multi-function terminal DI5 ON 0: OFF bit6 1: Multi-function terminal DI6 ON 0: OFF bit7 1: Multi-function terminal DI7 ON 0: OFF ... Bit31 1: Multi-function terminal DI7 ON 0: OFF
004FH~0050H	System output terminal status (24 ports) bit0 1: DO0 (Relay A) ON 0: OFF bit1 1: DO1 (Relay B) ON 0: OFF bit2 1: DO2 ON 0: OFF bit3 1: DO3 ON 0: OFF bit4 1: DO4 (OC) ON 0: OFF bit5 1: DO5 (OC) ON 0: OFF ... Bit23 1: DO5(OC) ON 0: OFF Bit24~Bit31 Not used ... Bit31 Not used

Register Address	Content
0051H	PLC extended output port () bit0 1: DO0 ON 0: OFF bit1 1: DO1 ON 0: OFF bit2 1: DO2 ON 0: OFF bit3 1: DO3 ON 0: OFF bit4 1: DO4 ON 0: OFF bit5 1: DO5 ON 0: OFF bit6 1: DO6 ON 0: OFF bit7 1: DO7 ON 0: OFF bit8 1: DO8 ON 0: OFF bit9 1: DO9 ON 0: OFF bit10 1: DO10 ON 0: OFF bit11 1: DO11 ON 0: OFF bit12 1: DO12 ON 0: OFF bit13 1: DO13 ON 0: OFF bit14 1: DO14 ON 0: OFF bit15 1: DO15 ON 0: OFF
0052H	Current frequency (unit: 0.01Hz)
0053H	Closed loop given frequency (unit: 0.01Hz)
0054H	Phase A bypass board status The 0th bit represents unit A1. If it is 1, the A1 unit is bypassed, and if it is 0, the A1 unit is normal. The nth bit represents the unit An. If it is 1, the An unit is bypassed, and if it is 0, the An unit is normal.
0055H	Phase B bypass board status Same as above
0056H	Phase C bypass board status Same as above
0057H	System Bypass Control Information Bit 0 indicates the system bypass type (1 for automatic, 0 for manual) The first bit indicates the system bypass enable (1 is enabled, 0 is disabled) and the second bit indicates the power frequency operation command (1 is start, 0 is stop) 3rd to 5th position: Reserved The 6th bit indicates the working mode or test mode (1 for test mode, 0 for working mode) The 7th digit indicates the system emergency stop (1 is emergency stop) 8th to 15th: Reserved
0058H	Target torque (0.1%, reference value motor rated torque), signed number
0059H	Output torque (0.1%, reference value motor rated torque), signed number

9.2 Profibus Protocol

9.2.1 Control Word

WORD	Content
WORD1	Operational control bit0: 1 forward, 0 invalid bit1: 1 inversion, 0 invalid bit2: 1 to run, 0 to stop bit3: 1 emergency stop, 0 invalid bit4: 1: power frequency to frequency conversion, 0: invalid bit5: 1 variable frequency to industrial frequency, 0 invalid bit6: 1: Pump emergency stop, 0: Invalid bit7: 1: start the power supply, 0: stop the power supply bit8: x bit9: x bit10: x bit11: x bit12: x bit13: x bit14: x bit15: x
WORD 2	Reserve
WORD 3	Reserve
WORD 4	Profibus frequency setting (0.01Hz); 0~6000
WORD 5	Reset Command bit0: reserved bit1: 1 self-check reset, 0 invalid bit2: 1 fault clear, 0 invalid bit3: reserved bit4: reserved bit5: reserved bit6: 1 power unit reset, 0 invalid bit7: 1 bypass board reset, 0 invalid bit8: x bit9: x bit10: x bit11: x bit12: x bit13: x bit14: x bit15: x

WORD	Content
WORD 6	bit0: 1 DO0 ON, 0 OFF bit1: 1 DO1 ON, 0 OFF bit2: 1 DO2 ON, 0 OFF bit3: 1 DO3 ON, 0 OFF bit4: 1 DO4 ON, 0 OFF bit5: 1 DO5ON, 0 OFF bit6: 1 DO6ON, 0 OFF bit7: 1 DO7ON, 0 OFF bit8: x bit9: x bit10: x bit11: x bit12: x bit13: x bit14: x bit15: x #Terminal output actual value = Profibus set value internal output value of function terminal
WORD 7	User multi-function input port [Refers to the input I/O of the user (Modbus master), so that the system (Modbus slave) can use the master as its own I/O] () bit0: 1 multi-function terminal DI0 ON, 0 OFF bit1: 1 multi-function terminal DI1 ON, 0 OFF bit2: 1 multi-function terminal DI2 ON, 0 OFF bit3: 1 multi-function terminal DI3 ON, 0 OFF bit4: 1 multi-function terminal DI4 ON, 0 OFF bit5: 1 multi-function terminal DI5 ON, 0 OFF bit6: 1 multi-function terminal DI6 ON, 0 OFF bit7: 1 multi-function terminal DI7 ON, 0 OFF bit8: 1 multi-function terminal DI8 ON , 0 OFF bit9: 1 multi-function terminal DI9 ON , 0 OFF bit10: 1 multi-function terminal DI10 ON , 0 OFF bit11: 1 multi-function terminal DI11 ON , 0 OFF bit12: 1 multi-function terminal DI12 ON , 0 OFF bit13: 1 multi-function terminal DI13 ON , 0 OFF bit14: 1 multi-function terminal DI14 ON , 0 OFF bit15: 1 multi-function terminal DI15 ON , 0 OFF
WORD 8	Enable water pump command bit0: 1 enables the first pump ON, 0 OFF bit1: 1 enables the second water pump ON, 0 OFF bit2: 1 enables the third pump ON, 0 OFF bit3: 1 enables the 4th pump ON, 0 OFF bit4: x bit5: x bit6: x bit7: x bit8: x bit9: x

WORD	Content
	bit10: x bit11: x bit12: x bit13: x bit14: x bit15: x
WORD9	Target torque (0.1%, reference value motor rated torque), signed number

9.2.2 Status word

WORD	Content
WORD 1	Drive status bit0: 1 self-test bit1: 1 alarm bit2: 1 Fault bit3: 1 unit bypass bit4: 1 system bypass bit5: 1 remote control, 0 local control bit6: 1 system closed loop control, 0 system open loop control bit7: 1 EEPROM initialization bit8: x bit9: x bit10: x bit11: x bit12: x bit13: x bit14: x bit15: x
WORD 2	Operating status bit0: 1 idle bit1: 1 forward start bit2: 1 forward bit3: 1 forward stop bit4: 1 reverse start bit5: 1 inversion bit6: 1 Reverse stop bit7: 1 forward->reverse bit8: 1 Reverse -> Forward bit9: x bit10: x bit11: x bit12: x bit13: x bit14: x bit15: x

WORD	Content
WORD3	Target frequency
WORD4	Current frequency
WORD 5	Current feedback speed
WORD 6	Current feedback frequency
WORD7	Closed loop given frequency
WORD 8	Output voltage effective value
WORD 9	Output current effective value
WORD 10	Input voltage RMS
WORD 11	Input current effective value
WORD 12	Output active power
WORD 13	Output reactive power
WORD 14	Total output power
WORD 15	Input power
WORD 16	Power Factor
WORD 17 WORD 18	<p>System input terminal status (32 ports, WORD 17 corresponds to 31~16bit, WORD 18 corresponds to 15~0bit)</p> <p>bit0: 1 multi-function terminal DI016ON, 0 OFF</p> <p>bit1: 1 multi-function terminal DI1 7ON, 0 OFF</p> <p>bit2: 1 multi-function terminal DI2 ON, 0 OFF</p> <p>bit3: 1 multi-function terminal DI3 ON, 0 OFF</p> <p>bit4: 1 multi-function terminal DI4 ON, 0 OFF</p> <p>bit5: 1 multi-function terminal DI5ON, 0 OFF</p> <p>bit6: 1 multi-function terminal DI6ON, 0 OFF</p> <p>bit7: 1 multi-function terminal DI7ON, 0 OFF</p> <p>bit8: 1 multi-function terminal DI8 ON, 0 OFF</p> <p>bit9: 1 multi-function terminal DI9 ON, 0 OFF</p> <p>bit10: 1 multi-function terminal DI10ON, 0 OFF</p> <p>bit11: 1 multi-function terminal DI11ON, 0 OFF</p> <p>bit12: 1 multi-function terminal DI12 ON, 0 OFF</p> <p>bit13: 1 multi-function terminal DI13 ON, 0 OFF</p> <p>bit14: 1 multi-function terminal DI14 ON, 0 OFF</p> <p>bit15: 1 multi-function terminal DI15 ON, 0 OFF</p> <p>bit16: 1 multi-function terminal DI16 ON, 0 OFF</p> <p>bit17: 1 multi-function terminal DI17ON, 0 OFF</p> <p>bit18: 1 multi-function terminal DI18ON, 0 OFF</p> <p>bit19: 1 multi-function terminal DI19ON, 0 OFF</p> <p>bit20: 1 multi-function terminal DI20 ON, 0 OFF</p>

WORD	Content
	bit21: 1 multi-function terminal DI21 ON, 0 OFF bit22: 1 multi-function terminal DI22ON, 0 OFF bit23: 1 multi-function terminal DI23 ON, 0 OFF bit24: 1 multi-function terminal DI24ON, 0 OFF bit25: 1 multi-function terminal DI25ON, 0 OFF bit26: 1 multi-function terminal DI26ON, 0 OFF bit27: 1 multi-function terminal DI27ON, 0 OFF bit28: 1 multi-function terminal DI28ON, 0 OFF bit29: 1 multi-function terminal DI29ON, 0 OFF bit30: 1 multi-function terminal DI30ON, 0 OFF bit31: 1 multi-function terminal DI31ON, 0 OFF
WORD 19 WORD 20	System output terminal status (24 ports) bit0: 1 DO0 ON, 0 OFF bit1: 1 DO1 ON, 0 OFF bit2: 1 DO2 ON, 0 OFF bit3: 1 DO3 ON, 0 OFF bit4: 1 DO4 ON, 0 OFF bit5: 1 DO5 ON, 0 OFF bit6: 1 DO6 ON, 0 OFF bit7: 1 DO7 ON, 0 OFF bit8: 1 DO8 ON, 0 OFF bit9: 1 DO9 ON, 0 OFF bit10: 1 DO10 ON, 0 OFF bit11: 1 DO11 ON, 0 OFF bit12: 1 DO12 ON, 0 OFF bit13: 1 DO13 ON, 0 OFF bit14: 1 DO14 ON, 0 OFF bit15: 1 DO15 ON, 0 OFF bit16: 1 DO16 ON, 0 OFF bit17: 1 DO17 ON, 0 OFF bit18: 1 DO18 ON, 0 OFF bit19: 1 DO19 ON, 0 OFF bit20: 1 DO20 ON, 0 OFF bit21: 1 DO21 ON, 0 OFF bit22: 1 DO22 ON, 0 OFF bit23: 1 DO23 ON, 0 OFF bit24: x bit25: x bit26: x bit27: x bit28: x bit29: x bit30: x bit31: x

WORD	Content
WORD 21	User multi-function output port () bit0: 1 DO0 ON, 0 OFF bit1: 1 DO1 ON, 0 OFF bit2: 1 DO2 ON, 0 OFF bit3: 1 DO3 ON, 0 OFF bit4: 1 DO4 ON, 0 OFF bit5: 1 DO5 ON, 0 OFF bit6: 1 DO6 ON, 0 OFF bit7: 1 DO7 ON, 0 OFF bit8: 1 DO8 ON, 0 OFF bit9: 1 DO9 ON, 0 OFF bit10: 1 DO10 ON, 0 OFF bit11: 1 DO11 ON, 0 OFF bit12: 1 DO12 ON, 0 OFF bit13: 1 DO13 ON, 0 OFF bit14: 1 DO14 ON, 0 OFF bit15: 1 DO15 ON, 0 OFF
WORD 22	Phase A bypass board status The 0th bit represents unit A1. If it is 1, the A1 unit is bypassed, and if it is 0, the A1 unit is normal. The nth bit represents the unit An. If it is 1, the An unit is bypassed, and if it is 0, the An unit is normal.
WORD 23	Phase B bypass board status Same as above
WORD 24	Phase C bypass board status Same as above
WORD 25	System Bypass Control Information Bit 0 indicates the system bypass type (1 for automatic, 0 for manual) Bit 1 indicates the system bypass enable (1 for enable, 0 for disable) The second bit indicates the power frequency operation command (1 for start, 0 for stop) 3rd to 5th position: Reserved The 6th bit indicates the working mode or test mode (1 for test mode, 0 for working mode) The 7th digit indicates the system emergency stop (1 is emergency stop) 8th to 15th: Reserved
WORD 26	Target torque (0.1%, reference value motor rated torque), signed number
WORD 27	Output torque (0.1%, reference value motor rated torque), signed number

Appendix A Fault List

NO.	Fault type	NO.	Fault type
0	A1 short circuit fault	25	C6 short circuit fault
1	A2 short circuit fault	26	C7 short circuit fault
2	A3 short circuit fault	27	C8 short circuit fault
3	A4 short circuit fault	28	C9 short circuit fault
4	A5 short circuit fault	29	C10 short circuit fault
5	A6 short circuit fault	30	A1 overvoltage fault
6	A7 short circuit fault	31	A2 overvoltage fault
7	A8 short circuit fault	32	A3 overvoltage fault
8	A9 short circuit fault	33	A4 overvoltage fault
9	A10 short circuit fault	34	A5 overvoltage fault
10	B1 short circuit fault	35	A6 overvoltage fault
11	B2 short circuit fault	36	A7 overvoltage fault
12	B3 short circuit fault	37	A8 overvoltage fault
13	B4 short circuit fault	38	A9 overvoltage fault
14	B5 short circuit fault	39	A10 overvoltage fault
15	B6 short circuit fault	40	B1 overvoltage fault
16	B7 short circuit fault	41	B2 overvoltage fault
17	B8 short circuit fault	42	B3 overvoltage fault
18	B9 short circuit fault	43	B4 overvoltage fault
19	B10 short circuit fault	44	B5 overvoltage fault
20	C1 short circuit fault	45	B6 overvoltage fault
twenty one	C2 short circuit fault	46	B7 overvoltage fault
twenty two	C3 short circuit fault	47	B8 overvoltage fault
twenty three	C4 short circuit fault	48	B9 overvoltage fault
twenty four	C5 short circuit fault	49	B10 overvoltage fault
50	C1 overvoltage fault	79	B10 Overheating Fault
51	C2 overvoltage fault	80	C1 overheat fault
52	C3 overvoltage fault	81	C2 overheating fault
53	C4 overvoltage fault	82	C3 overheating fault
54	C5 overvoltage fault	83	C4 overheating fault
55	C6 overvoltage fault	84	C5 overheating fault
56	C7 overvoltage fault	85	C6 overheating fault
57	C8 overvoltage fault	86	C7 overheating fault
58	C9 overvoltage fault	87	C8 overheating fault

NO.	Fault type	NO.	Fault type
59	C10 overvoltage fault	88	C9 overheating fault
60	A1 overheating fault	89	C10 Overheating Fault
61	A2 Overheating Fault	90	A1 voltage balancing failure
62	A3 Overheating Fault	91	A2 pressure equalization failure
63	A4 overheating fault	92	A3 pressure equalization failure
64	A5 overheating fault	93	A4 voltage balancing failure
65	A6 overheating fault	94	A5 voltage balancing failure
66	A7 overheating failure	95	A6 voltage balancing failure
67	A8 overheating failure	96	A7 voltage balancing failure
68	A9 Overheating Failure	97	A8 voltage balancing failure
69	A10 overheating fault	98	A9 voltage balancing failure
70	B1 Overheat Fault	99	A10 voltage balancing failure
71	B2 Overheat Fault	100	B1 voltage balancing failure
72	B3 Overheating Fault	101	B2 pressure equalization failure
73	B4 Overheating Fault	102	B3 pressure equalization failure
74	B5 Overheating Failure	103	B4 pressure equalization failure
75	B6 Overheating Fault	104	B5 pressure equalization failure
76	B7 Overheating Fault	105	B6 pressure equalization failure
77	B8 overheating fault	106	B7 pressure equalization failure
78	B9 Overheating Fault	107	B8 pressure equalization failure
108	B9 pressure equalization failure	137	B8 Uplink fiber failure
109	B10 pressure equalization failure	138	B9 Uplink fiber failure
110	C1 voltage balancing failure	139	B10 Uplink fiber failure
111	C2 voltage balancing failure	140	C1 upstream fiber failure
112	C3 voltage balancing failure	141	C2 upstream fiber failure
113	C4 voltage balancing failure	142	C3 Uplink fiber failure
114	C5 voltage balancing failure	143	C4 Uplink fiber failure
115	C6 voltage balancing failure	144	C5 Uplink fiber failure
116	C7 voltage balancing failure	145	C6 Uplink fiber failure
117	C8 voltage balancing failure	146	C7 Uplink fiber failure
118	C9 voltage balancing failure	147	C8 Uplink fiber failure
119	C10 voltage balancing failure	148	C9 upstream optical fiber failure
120	A1 Uplink Fiber Failure	149	C10 Uplink fiber failure
121	A2 Uplink fiber failure	150	A1 Downlink Fiber Failure
122	A3 Uplink fiber failure	151	A2 Downlink Fiber Failure
123	A4 Uplink fiber failure	152	A3 Downlink fiber failure

NO.	Fault type	NO.	Fault type
124	A5 Uplink fiber failure	153	A4 Downlink fiber failure
125	A6 Uplink fiber failure	154	A5 Downlink fiber failure
126	A7 Uplink fiber failure	155	A6 Downlink fiber failure
127	A8 Uplink fiber failure	156	A7 Downlink fiber failure
128	A9 Uplink fiber failure	157	A8 Downlink fiber failure
129	A10 Uplink fiber failure	158	A9 Downlink fiber failure
130	B1 upstream fiber failure	159	A10 Downlink fiber failure
131	B2 upstream fiber failure	160	B1 Downlink Fiber Failure
132	B3 Uplink fiber failure	161	B2 Downlink Fiber Failure
133	B4 Uplink fiber failure	162	B3 Downlink fiber failure
134	B5 Uplink fiber failure	163	B4 Downlink fiber failure
135	B6 Uplink fiber failure	164	B5 Downlink fiber failure
136	B7 Uplink fiber failure	165	B6 Downlink fiber failure
166	B7 Downlink fiber failure	195	Output phase imbalance
167	B8 Downlink fiber failure	196	Output side overvoltage
168	B9 Downlink fiber failure	197	CAN communication failure
169	B10 Downlink fiber failure	198	Manual communication failure
170	C1 downstream fiber failure	199	Fiber optic communication failure
171	C2 downstream fiber failure	200	HMI communication failure
172	C3 Downlink Fiber Failure	201	Bypass board uplink communication failure
173	C4 Downlink Fiber Failure	202	Bypass board downstream communication failure
174	C5 Downlink fiber failure	203	Watchdog reset fault
175	C6 Downlink fiber failure	204	Cabinet door open
176	C7 Downlink Fiber Failure	205	Transformer overheating
177	C8 Downlink fiber failure	206	Transformer fan 1 thermal relay tripped
178	C9 Downlink Fiber Failure	207	Transformer fan 2 thermal relay tripped
179	C10 Downlink fiber failure	208	Unit fan 1 thermal relay tripped
180	Speeding	209	Unit fan 2 thermal relay tripped
181	overload	210	Unit fan 3 thermal relay tripped
182	Underload	211	UPS failure, i.e. medium voltage power failure
183	Motor overheating	212	Phase A bypass fault
184	Input side overcurrent	213	Phase B bypass fault
185	Input side phase loss	214	Phase C bypass fault
186	Input ground fault	215	The fan is not powered on.

NO.	Fault type	NO.	Fault type
187	Input phase imbalance	216	User external fault 0 , low level fault
188	Input side undervoltage	217	User external fault 1, high level fault
189	Output side overvoltage	218	Transformer overheating (sensor detection)
190	Output side overcurrent	219	Overheating
191	Output side phase loss	220	Excessive humidity
192	Output ground fault	221	RTC Failure
193	Output open circuit	222	Modbus communication failure
194	Output instantaneous overcurrent	223	Analog disconnection fault
224	Profibus communication failure	253	B4PWM lockout fault
225	Input power off	254	B5PWM blocking fault
226	Vacuum contactor K1 fault	255	B6PWM blocking fault
227	Vacuum contactor K2 fault	256	B7PWM lockout fault
228	Vacuum contactor K3 fault	257	B8PWM blocking fault
229	Vacuum contactor K4 failure (spare)	258	B9PWM lockout fault
230	Vacuum contactor K5 failure (spare)	259	B10PWM blocking fault
231	Vacuum contactor K6 failure (spare)	260	C1PWM lockout fault
232	One-to-four first power frequency connection failure	261	C2PWM Lockout Fault
233	One-to-four second power frequency connection failure	262	C3PWM Lockout Fault
234	One-to-four third power frequency connection failure	263	C4PWM Lockout Fault
235	One-to-four fourth power frequency connection fault	264	C5PWM lockout fault
236	External 380V power supply failure	265	C6PWM lockout fault
237	The phase sequence of power frequency conversion is inconsistent	266	C7PWM lockout fault
238	Vacuum contactors act simultaneously	267	C8PWM lockout fault
239	IO expansion board CAN communication failure	268	C9PWM lockout fault
240	A1PWM lockout fault	269	C10PWM lockout fault
241	A2PWM lockout fault	270	A1PWM turn on fault
242	A3PWM blocking fault	271	A2PWM turn on fault
243	A4PWM lockout fault	272	A3PWM start failure
244	A5PWM lockout fault	273	A4PWM turn on fault
245	A6PWM lockout fault	274	A5PWM turn on fault
246	A7PWM lockout fault	275	A6PWM start failure
247	A8PWM lockout fault	276	A7PWM turn on failure

NO.	Fault type	NO.	Fault type
248	A9PWM lockout fault	277	A8PWM start failure
249	A10PWM lockout fault	278	A9PWM start failure
250	B1PWM blocking fault	279	A10PWM start failure
251	B2PWM Blockage Fault	280	B1PWM turn on fault
25 2	B3PWM lockout fault	281	B2PWM turn on fault
282	B3PWM turn on fault	311	B1 phase failure
283	B4PWM start failure	312	B2 phase failure
284	B5PWM start failure	313	B3 phase failure
285	B6PWM start fault	314	B4 phase failure
286	B7PWM start failure	315	B5 phase failure
287	B8PWM start failure	316	B6 phase failure
288	B9PWM start failure	317	B7 phase failure
289	B10PWM start failure	318	B8 phase failure
290	C1PWM turn-on fault	319	B9 phase failure
291	C2PWM turn-on fault	320	B10 phase failure
292	C3PWM turn-on fault	321	C1 phase failure
293	C4PWM start fault	322	C2 phase failure
294	C5PWM start failure	323	C3 phase failure
295	C6PWM start fault	324	C4 phase failure
296	C7PWM start failure	325	C5 phase failure
297	C8PWM start failure	326	C6 phase failure
298	C9PWM start failure	327	C7 phase failure
299	C10PWM start failure	328	C8 phase failure
300	Acquisition board CAN communication failure	329	C9 phase failure
301	A1 phase failure	330	C10 phase failure
302	A2 phase failure		
303	A3 phase failure		
304	A4 phase failure		
305	A5 phase failure		
306	A6 phase failure		
307	A7 phase failure		
308	A8 phase failure		
309	A9 phase failure		
310	A10 phase failure		

Appendix B Customer Complaint

Client's name:	
Telephone:	fax:
Complaint category: <input type="checkbox"/> Sales <input type="checkbox"/> Promotion <input type="checkbox"/> Service <input type="checkbox"/> Quality <input type="checkbox"/> Business <input type="checkbox"/> Product <input type="checkbox"/> Other	
Complaints:	
Complainant (Signature): Complaint unit (official seal): Date: Year Month Day	

APPENDIX C:

QUALITY CERTIFICATION AND WARRANTY LETTER CARD

WARRANTY LETTER
Customer name: _____
Address: _____
Contact : _____ Telephone: _____
Model: _____
Product code: _____
Purchase date: _____ Fault date: _____
Available motor: _____ Equipment name: _____
Fault instruction: _____

Remarks: please send this card and the faulty product together to our company. Thanks

QUALITY CERTIFICATION
Inspection people: _____
Date: _____
After our strict inspection based on the product testing before delivery, it has met the standard of our manual regulation and is ready for delivery.

Warranty Agreement

1. The warranty period of this product is eighteen months (subject to the barcode information on the body). During the warranty period, if the product fails or is damaged under normal use according to the instruction manual, the company will be responsible for free repair.
2. During the warranty period, a certain repair fee will be charged for damage caused by the following reasons:
 - A. Damage to the machine caused by incorrect use and unauthorized repair or modification;
 - B. Damage to the machine caused by fire, flood, abnormal voltage, other natural disasters and secondary disasters;
 - C. Hardware damage caused by human dropping and transportation after purchase;
 - D. Damage to the machine caused by failure to operate according to the user manual provided by the company;
 - E. Failure and damage caused by obstacles other than the machine (such as external equipment factors);
3. When the product fails or is damaged, please fill in the contents of the "Product Warranty Card" correctly and in detail.
4. The collection of repair fees shall be based on the "Repair Price List" newly adjusted by the company.
5. This warranty card will not be reissued under normal circumstances. Please keep this card and show it to the maintenance personnel during warranty.
6. If you have any questions during the service process, please contact our engineering center in time.
7. The right to interpret this agreement belongs to our company.

Appendix D Letter to Customers

Dear Customer:

RoHS is the abbreviation of "Restriction of the Use of Certain Hazardous Substances in Electrical and Electronic Equipment". The EU implemented the RoHS directive on July 1, 2006, which stipulates that the use of six hazardous substances, including lead, mercury, cadmium, hexavalent chromium, polybrominated biphenyls (PBB) and polybrominated diphenyl ethers (PBDE), is restricted in new electronic and electrical equipment products.

On February 28, 2006, the seven ministries and commissions of my country, including the Ministry of Information Industry, the Development and Reform Commission, the Ministry of Commerce, the General Administration of Customs, the State Administration for Industry and Commerce, the General Administration of Quality Supervision, Inspection and Quarantine, and the State Environmental Protection Administration, jointly promulgated the "Measures for the Control of Pollution by Electronic Information Products", which became the Chinese version of the RoHS directive and was enforced. On February 1, 2008, the "Measures for the Prevention and Control of Environmental Pollution by Electronic Waste" promulgated by the State Environmental Protection Administration of the People's Republic of China has begun to be implemented. The management measures clearly stipulate that users of electronic and electrical products should provide or entrust electronic waste to dismantling, utilization or disposal units (including individual industrial and commercial households) listed in the list (including the temporary list) with corresponding business scope for dismantling, utilization or disposal.

Our company strictly controls six hazardous substances including lead, mercury, cadmium, hexavalent chromium, polybrominated biphenyls and polybrominated diphenyl ethers in the selection and procurement of electronic components, PCB boards, wiring harness materials, and structural parts. At the same time, during the production process, PCB components are welded on the Xinchu lead-free welding production line using lead-free welding technology.

The following component products may contain toxic and harmful elements:

Component Type	Electronic component	Electronic printed circuit boards (PCB boards)	Sheet Metal	heat sink	Plastic parts	wire
Possible toxic and harmful elements	Six harmful substances including lead, mercury, cadmium, hexavalent chromium, polybrominated biphenyls and polybrominated diphenyl ethers					

1. Environmental impact analysis

Our company's electronic products will generate some heat during use, which may cause trace amounts of individual harmful substances to be emitted, but will not cause serious impact on the surrounding environment. Once the life cycle of electronic products ends and they are discarded, the heavy metals and chemical toxic and harmful substances in them will cause serious pollution to soil and water resources.

2. Life cycle of electronic products and equipment

Any electronic product and equipment has a service life and will be damaged and scrapped. Even if it can still be used, it will be eliminated by the upgrading of electronic products. The life cycle of our company's electronic products and equipment generally does not exceed 20 years.

3. Disposal of scrapped electronic products

When various electronic products are scrapped, improper handling will pollute the environment. Our company requires customers to establish a recycling system in accordance with relevant national regulations, and shall not discard them as general domestic waste or general industrial solid waste. They should strictly implement the "Management Measures for the Prevention and Control of Environmental Pollution by Electronic Waste" issued by the State Environmental Protection Administration, store and use them in an environmentally harmless manner, or ask qualified units to uniformly recycle and treat them. Any unqualified individuals and units are prohibited from engaging in the dismantling, utilization, and disposal of electronic waste.

Please do not discard electronic waste with ordinary household waste. Call your local waste disposal agency or environmental agency for advice on disposing of your electronic waste.

